

- Globe valves, 2-way, with flange PN 6
- for closed cold and warm water systems
  - for modulating water-side control of air handling units and heating systems

**Type overview**

Type	$k_{vs}$ [m <sup>3</sup> /h]	DN [mm]	Stroke [mm]	$S_v$
H611R	0.63	15	15	>50
H612R	1	15	15	>50
H613R	1.6	15	15	>50
H614R	2.5	15	15	>50
H615R	4	15	15	>50
H620R	6.3	20	15	>100
H625R	10	25	15	>100
H632R	16	32	15	>100
H640R	25	40	15	>100
H650R	40	50	15	>100
H664R	58	65	18	>100
H679R	90	80	18	>100
H6100R	145	100	30	>100

**Technical data**

<b>Functional data</b>	Flow media	Cold and warm water, water with max. 50% volume of glycol
	Temperature of medium	(-10 °C) +5 °C...+120 °C (-10 °C on request)
	Rated pressure $p_s$	600 kPa (PN 6)
	Flow characteristic	Control path A – AB: equal percentage (to VDI/VDE 2173) $n(gl) = 3$ , optimized in the opening range
	Rangeability $S_v$	See «Type overview»
	Leakage rate	Control path A – AB: leakage class III (DIN EN 1349 and DIN EN 60534-4)
	Pipe connection	Flange to ISO 7005-2 (PN 6)
	Stroke	See «Type overview»
	Valve closing point	Up (▲)
	Installation position	Upright to horizontal (in relation to the stem)
<b>Materials</b>	Maintenance	Maintenance-free
	Fitting	Cast iron GG25
	Valve cone	Stainless steel
	Valve stem	Stainless steel
	Valve seat	Cast iron GG25 / Niro (bypass)
<b>Dimensions / Weights</b>	Stem gland seal	EPDM O-ring
	Dimensions and weights	See «Dimensions and weights», page 3
<b>Motorizing</b>	See the Complete overview «The complete range of water solutions»	

### Safety notes



- This globe valve has been designed for use in stationary heating, ventilation and air conditioning systems and is not allowed to be used outside the specified field of application, especially in aircraft or in any other airborne means of transport.
- It may only be installed by suitably trained personnel.
- All applicable legal or institutional installation regulations must be complied with.
- The valve does not contain any parts that can be replaced or repaired by the user.
- The valve is not allowed to be disposed of as household refuse. All locally valid regulations and requirements must be observed.
- The recognized rules should be applied when determining the flow characteristic of final controlling elements.

### Product features

- Mode of operation** The globe valve is operated by an NV or AV series linear actuator. The linear actuators are controlled by a standard modulating or 3-point control system and move the cone of the valve, the throttling device, to the opening position dictated by the control signal.
- Flow characteristic** An equal-percentage flow characteristic is produced by profiling the valve cone.
- Manual operation** On the NV or AV linear actuator, the valve stem can be actuated manually using a hexagonal key.

### Installation notes

- Recommended mounting positions** The globe valve may be mounted either **vertically** or **horizontally**. It is not permissible, mounting the globe valve with the stem pointing downwards.

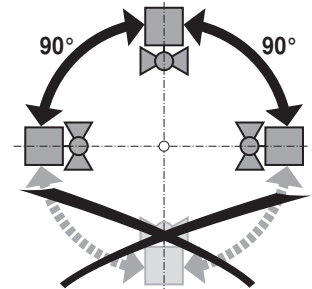

- Water quality requirements**
- The water quality requirements specified in VDI 2035 must be adhered to.
  - Globe valves are relatively sensitive control devices. In order to ensure a long service life, it is advisable to fit **strainers**.
- Maintenance**
- The globe valves and linear actuators are maintenance-free.
  - Before any kind of service work is carried out on actuator sets of this type, it is essential to isolate the linear actuator from the power supply (by unplugging the power lead). Any pumps in the part of the piping system concerned must also be switched off and the appropriate isolating fittings closed (allow everything to cool down first if necessary and reduce the pressure in the system to atmospheric).
  - The system must not be returned to service until the globe valve and the linear actuator have been properly reassembled in accordance with the instructions and the pipework has been refilled in the proper manner.
- Direction of flow** The direction of flow, specified by an arrow on the housing, is to be complied with, since otherwise the globe valve can be damaged.

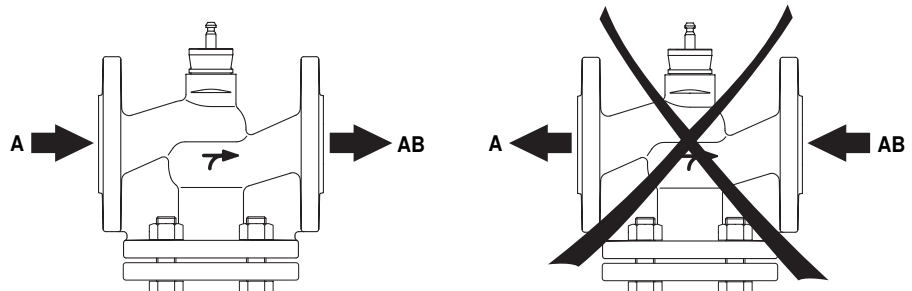

## Accessories

	Description
Mechanical accessories	Stem heating ZH24-1 (45 W), DN 15...50
	ZH24-1-C (60 W), DN 65...100

## Dimensions and weights

## Dimensional drawings

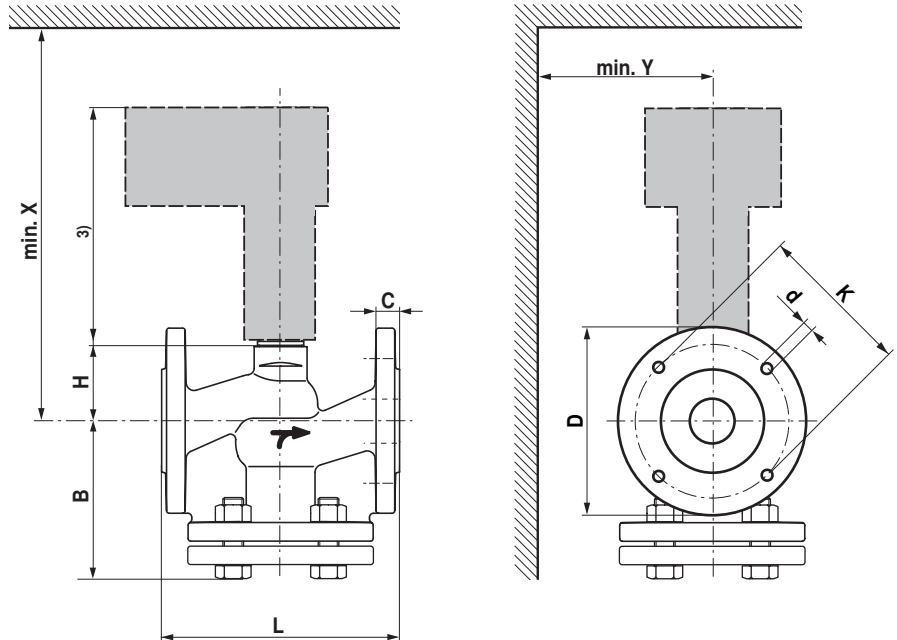

DN [mm]	L [mm]	H [mm]	B [mm]	D [mm]	C [mm]	K [mm]	d [mm]	X <sup>1)</sup> [mm]	Y <sup>1)</sup> [mm]	X <sup>2)</sup> [mm]	Y <sup>2)</sup> [mm]	Weight [kg]
15	130	46	86	80	14	55	4x11	470	100			2.9
20	150	46	93	90	16	65	4x11	470	100			3.9
25	160	52	98	100	16	75	4x11	470	100			4.8
32	180	56	119	120	18	90	4x14	470	100			7.0
40	200	64	124	130	18	100	4x14	470	100			9.3
50	230	64	124	140	20	110	4x14	470	100			10.8
65	290	100	144	160	20	130	4x14	515	100	665	150	18.0
80	310	110	158	190	22	150	4x18	515	100	665	150	25.3
100	350	125	178	210	24	170	4x18			665	150	37.1

<sup>1)</sup> Minimum distance with respect to the valve centre with actuator NV..

<sup>2)</sup> Minimum distance with respect to the valve centre with actuator AV..

<sup>3)</sup> The actuator dimensions can be found on the respective actuator data sheet.

## Further documentations

- Complete overview «The complete range of water solutions»
- Data sheets actuators
- Installation instructions for globe valves and/or actuators
- Notes for project planning (hydraulic characteristic curves and circuits, installation regulations, commissioning, maintenance etc.)