

- Globe valves, 3-way, with flange PN 6
- for closed cold and warm water systems
 - for modulating water-side control of air handling units and heating systems



Type overview

Type	k_{vs} [m ³ /h]	DN [mm]	Stroke [mm]	S_v
H711R	0.63	15	15	>50
H712R	1	15	15	>50
H713R	1.6	15	15	>50
H714R	2.5	15	15	>50
H715R	4	15	15	>50
H720R	6.3	20	15	>100
H725R	10	25	15	>100
H732R	16	32	15	>100
H740R	25	40	15	>100
H750R	40	50	15	>100
H764R	58	65	18	>100
H779R	90	80	18	>100
H7100R	145	100	30	>100

Technical data

Functional data	Flow media	Cold and warm water, water with max. 50% volume of glycol	
	Temperature of medium	(-10 °C) +5 °C...+120 °C (-10 °C on request)	
	Rated pressure p_s	600 kPa (PN 6)	
	Flow characteristic	Control path A – AB: equal percentage (to VDI/VDE 2173) $n(gl) = 3$, optimized in the opening range bypass B – AB: linear (to VDI/VDE 2173)	
	Rangeability S_v	See «Type overview»	
	Leakage rate	Control path A – AB: leakage class III (DIN EN 1349 and DIN EN 60534-4) bypass B – AB: max. 1% of k_{vs} value	
	Pipe connection	Flange to ISO 7005-2 (PN 6)	
	Stroke	See «Type overview»	
	Valve closing point	Up (▲)	
	Installation position	Upright to horizontal (in relation to the stem)	
	Maintenance	Maintenance-free	
	Materials	Fitting	Cast iron GG25
		Valve cone	Stainless steel
Valve stem		Stainless steel	
Valve seat		Cast iron GG25 / Niro (bypass)	
Stem gland seal		EPDM O-ring	
Dimensions / Weights	Dimensions and weights	See «Dimensions and weights», page 3	
Motorizing	See the Complete overview «The complete range of water solutions»		

Safety notes



- This globe valve has been designed for use in stationary heating, ventilation and air conditioning systems and is not allowed to be used outside the specified field of application, especially in aircraft or in any other airborne means of transport.
- It may only be installed by suitably trained personnel.
All applicable legal or institutional installation regulations must be complied with.
- The valve does not contain any parts that can be replaced or repaired by the user.
- The valve is not allowed to be disposed of as household refuse. All locally valid regulations and requirements must be observed.
- The recognized rules should be applied when determining the flow characteristic of final controlling elements.

Product features

- Mode of operation** The globe valve is operated by an NV series linear actuator. The linear actuators are controlled by a standard modulating or 3-point control system and move the cone of the valve, the throttling device, to the opening position dictated by the control signal.
- Flow characteristic** An equal-percentage flow characteristic is produced by profiling the valve cone. The bypass exhibits a linear characteristic curve.
- Manual operation** On the NV linear actuator, the valve stem can be actuated manually using a hexagonal key.

Installation notes

- Recommended mounting positions** The globe valve may be mounted either **vertically** or **horizontally**. It is not permissible, mounting the globe valve with the stem pointing downwards.

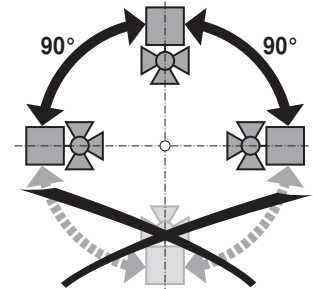

- Water quality requirements**
- The water quality requirements specified in VDI 2035 must be adhered to.
 - Globe valves are relatively sensitive control devices. In order to ensure a long service life, it is advisable to fit **strainers**.
- Maintenance**
- The globe valves and linear actuators are maintenance-free.
 - Before any kind of service work is carried out on actuator sets of this type, it is essential to isolate the linear actuator from the power supply (by unplugging the power lead). Any pumps in the part of the piping system concerned must also be switched off and the appropriate isolating fittings closed (allow everything to cool down first if necessary and reduce the pressure in the system to atmospheric).
 - The system must not be returned to service until the globe valve and the linear actuator have been properly reassembled in accordance with the instructions and the pipework has been refilled in the proper manner.
- Direction of flow** The direction of flow, specified by an arrow on the housing, is to be complied with, since otherwise the globe valve can be damaged.

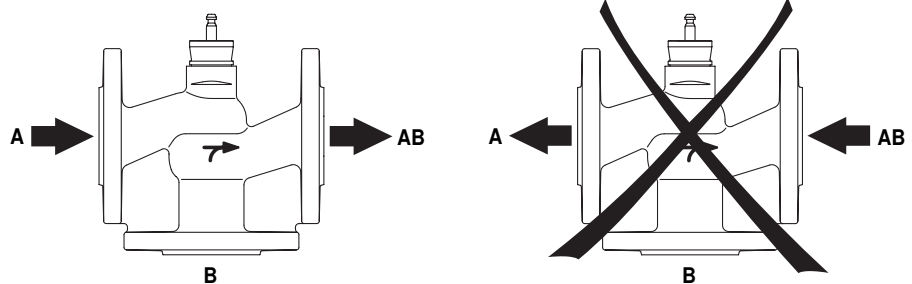

Accessories

Mechanical accessories

Description

Stem heating ZH24-1 (45 W), DN 15...50
ZH24-1-C (60 W), DN 65...100

Blanked flange for sealing the bypass ZH7..

Dimensions and weights

Dimensional drawings

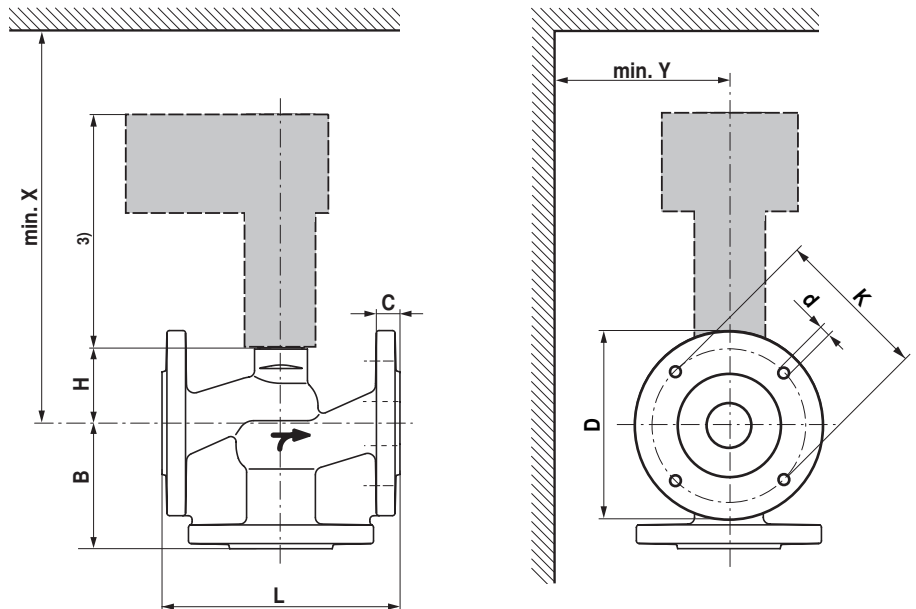

DN	L	H	B	D	C	K	d	X ¹⁾	Y ¹⁾	X ²⁾	Y ²⁾	Gewicht
[mm]	[mm]	[mm]	[mm]	[mm]	[mm]	[mm]	[mm]	[mm]	[mm]	[mm]	[mm]	[kg]
15	130	46	65	80	12	55	4x11	470	100			2.8
20	150	46	70	90	14	65	4x11	470	100			3.7
25	160	52	75	100	14	75	4x11	470	100			4.7
32	180	56	95	120	16	90	4x14	470	100			7.2
40	200	64	100	130	16	100	4x14	470	100			9.2
50	230	64	100	140	16	110	4x14	470	100			12.2
65	290	100	120	160	16	130	4x14	515	100	665	150	19.0
80	310	110	130	190	18	150	4x18	515	100	665	150	24.0
100	350	125	150	210	18	170	4x18			665	150	34.0

¹⁾ Minimum distance with respect to the valve centre with actuator NV..

²⁾ Minimum distance with respect to the valve centre with actuator AV..

³⁾ The actuator dimensions can be found on the respective actuator data sheet.

Further documentations

- Complete overview «The complete range of water solutions»
- Data sheets actuators
- Installation instructions for globe valves and/or actuators
- Notes for project planning (hydraulic characteristic curves and circuits, installation regulations, commissioning, maintenance etc.)