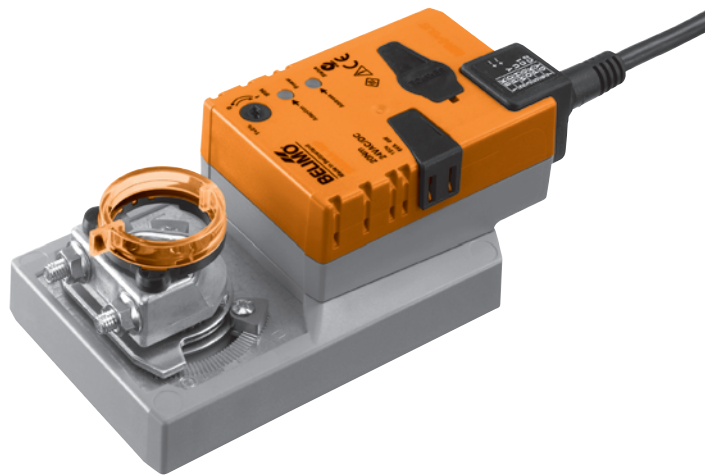

Multifunctional damper actuator for adjusting air dampers in ventilation and air-conditioning systems for building services installations

- For air dampers up to approx. 4 m²
- Torque 20 Nm
- Nominal voltage AC/DC 24 V
- Control: Modulating DC 0 ... 10 V or variable
- Position feedback DC 2 ... 10 V or variable

Technical data
Electrical data

Nominal voltage	AC 24 V, 50/60 Hz / DC 24 V
Nominal voltage range	AC 19.2 ... 28.8 V / DC 21.6 ... 28.8 V
Power consumption	4 W @ nominal torque
At rest	1.25 W
For wire sizing	6 VA
Connection	Cable 1 m, 4 x 0.75 mm ²

Functional data	Factory settings	Variable	Settings
Torque (nominal torque)	Min. 20 Nm @ nominal voltage	25%, 50%, 75% reduziert
Control Control signal Y	DC 0 ... 10 V, input impedance 100 kΩ	Open-close, 3-point (AC only), modulating (DC 0 ... 32 V)
Operating range	DC 2 ... 10 V	Start point DC 0.5 ... 30 V End point DC 2.5 ... 32 V
Position feedback (Measuring voltage U)	DC 2 ... 10 V, max. 0.5 mA	Start point DC 0.5 ... 8 V End point DC 2.5 ... 10 V
Position accuracy	±5%		
Direction of rotation	Reversible with switch 0 / 1		
Direction of motion at Y = 0 V	In switch position 0 ↻ resp. 1 ↻	Electronically reversible
Manual override	Gearing latch disengaged with pushbutton, can be locked		
Angle of rotation	Max. 95° ↻, can be limited at both ends with adjustable mechanical end stops		
Running time	150 s / 90° ↻	86 ... 346 s
Automatic adjustment running time, operating range and measuring signal U to match the mechanical angle of rotation	Manual triggering of the adaption by pressing the «Adaption» button or with the PC-Tool	Automatic adaption whenever the supply voltage is switched on, or manual triggering
Override control	MAX (maximum position) = 100% MIN (minimum position) = 0% ZS (intermediate position, AC only) = 50%	MAX = (MIN + 30° ↻) ... 100% MIN = 0% ... (MAX - 30° ↻) ZS = MIN ... MAX
Sound power level	Max. 45 dB (A)	With a 86 s = 45 dB (A) running time 346 s = <35 dB (A)	
Position indication	Mechanical, pluggable		

Safety

Protection class	III Safety extra-low voltage / UL Class 2 Supply
Degree of protection	IP54 in any mounting position NEMA 2, UL Enclosure Type 2
EMC	CE according to 2004/108/EC
Certification	cULus according to UL 60730-1A and UL 60730-2-14 and CAN/CSA E60730-1:02 Certified to IEC/EN 60730-1 and IEC/EN 60730-2-14
Mode of operation	Type 1
Rated impulse voltage	0.8 kV
Control pollution degree	3
Ambient temperature	-30 ... +50 °C
Non-operating temperature	-40 ... +80 °C
Ambient humidity	95% r.h., non-condensating
Maintenance	Maintenance-free

Technical data *(Continued)*
Dimensions / Weight





Dimensions	See «Dimensions» on page 5
Weight	ca. 920 g

Safety notes

- The actuator is not allowed to be used outside the specified field of application, especially in aircraft or any other form of air transport.
- Assembly must be carried out by trained personnel. Any legal regulations or regulations issued by authorities must be observed during assembly.
- The device may only be opened at the manufacturer's site. It does not contain any parts that can be replaced or repaired by the user.
- The cable must not be removed from the device.
- When calculating the required torque, the specifications supplied by the damper manufacturers (cross section, design, installation site), and the air flow conditions must be observed.
- The device contains electrical and electronic components and is not allowed to be disposed of as household refuse. All locally valid regulations and requirements must be observed.

Product features

Mode of operation	The actuator is controlled with a standard modulating signal of DC 0 ... 10 V and travels to the position defined by the control signal. Measuring voltage U serves for the electrical display of the damper position 0 ... 100% and as slave control signal for other actuators.
Parameterisable actuators	The factory settings cover the most common applications. Input and output signals and other parameters can be altered with the MFT-H parameterising device or the BELIMO Service Tool, MFT-P.
Simple direct mounting	Simple direct mounting on the damper spindle with a universal spindle clamp, supplied with an anti-rotation strap to prevent the actuator from rotating.
Manual override	Manual operation is possible with the pushbutton (the gearing latch remains disengaged as long as the pushbutton is pressed or detented).
Adjustable angle of rotation	Adjustable angle of rotation with mechanical end stops.
High functional reliability	The actuator is overload-proof, requires no limit switches and automatically stops when the end stop is reached.
Home position	When the supply voltage is switched on for the first time, i.e. at commissioning or after pressing the «gear disengagement» switch, the actuator travels to the home position.

Pos. direction of rotation switch	Home position
 Y = 0 	 Left stop
Y = 1 	 Right stop

The actuator then moves into the position defined by the control signal.

Accessories

	Description	Data sheet
Electrical accessories	Auxiliary switch S..A..	T2 - S..A..
	Feedback potentiometer P..A..	T2 - P..A..
	PC-Tool MFT-P from version 3.3	T2 - MFT-P
	Parameterising device MFT-H	T2 - MFT-H
	Position sensor SGA24, SGE24 and SGF24	T2 - SG..24
	Digital position indication ZAD24	T2 - ZAD24
Mechanical accessories	Various accessories (clamps, shaft extensions etc.)	T2 - Z-SM..A..

Electrical installation

Wiring diagram

Notes

- Connection via safety isolating transformer!
- Other actuators can be connected in parallel. Please note the performance data!

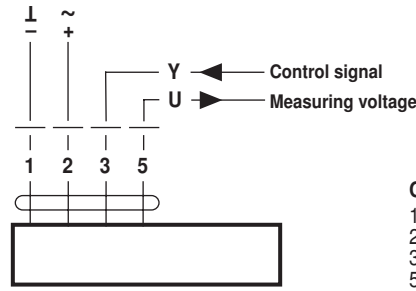

Cable colours:

- 1 = black
- 2 = red
- 3 = white
- 5 = orange

Functions with basic values

Override control with AC 24 V with relay contacts

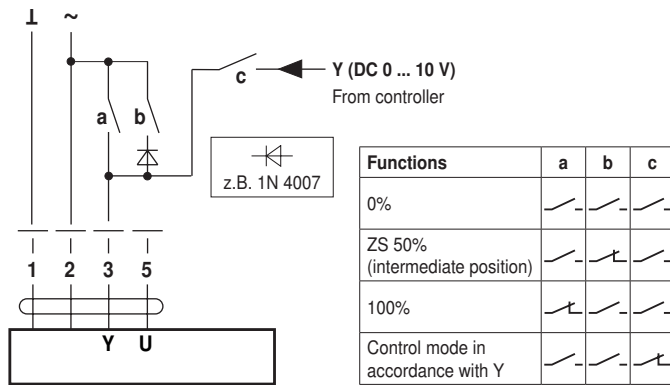

Override control with AC 24 V with rotary control switch

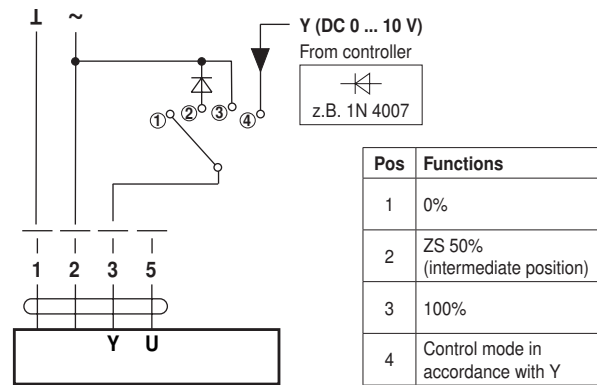

Remote control 0 ... 100 %

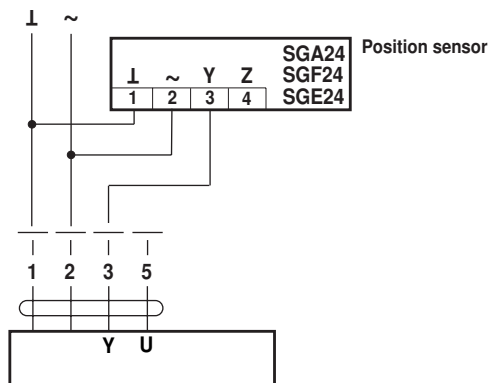

Minimum limit

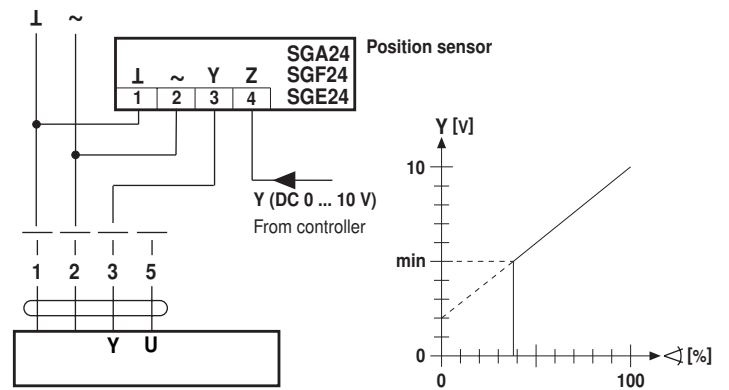

Master/Slave control (position-dependent)

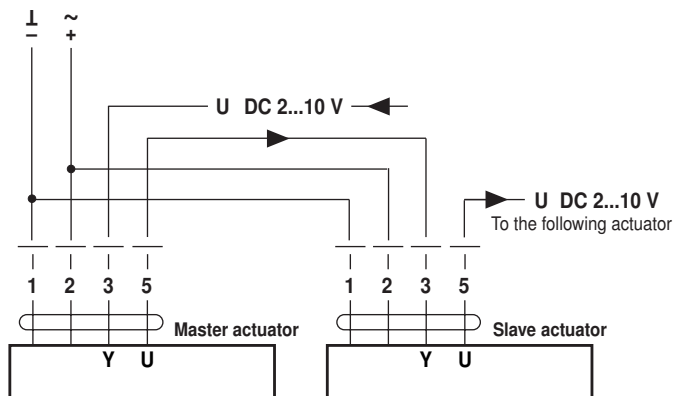

Control with 4 ... 20 mA via external resistance

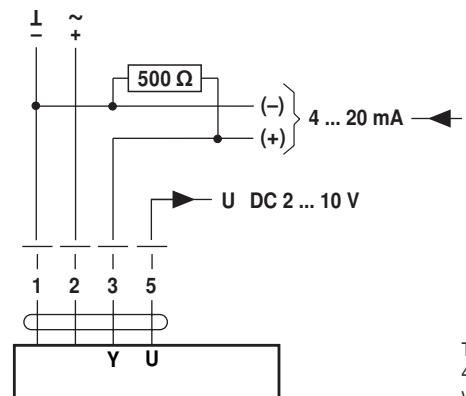

The 500 Ω resistor converts the 4 ... 20 mA current signal to a voltage signal DC 2 ... 10 V

Functions with basic values (Continued)

Position indication

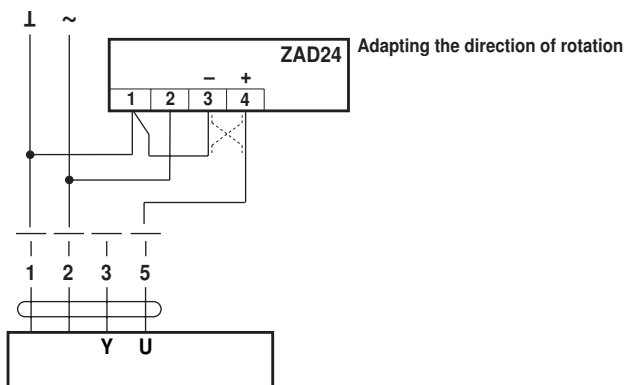

Functional check

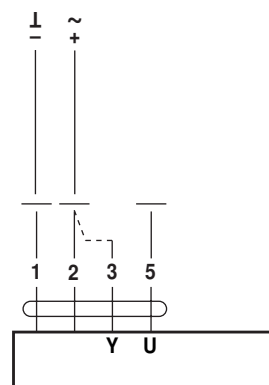

Procedure

- Apply 24 V to connection 1 and 2
- Disconnect connection 3:
 - For direction of rotation 0: Actuator turns in the direction of ↺
 - For direction of rotation 1: Actuator turns in the direction of ↻
- Short circuit connections 2 and 3:
 - Actuator travels in the opposite direction

Functions for actuators with specific parameters

Override control and limiting with AC 24 V with relay contacts

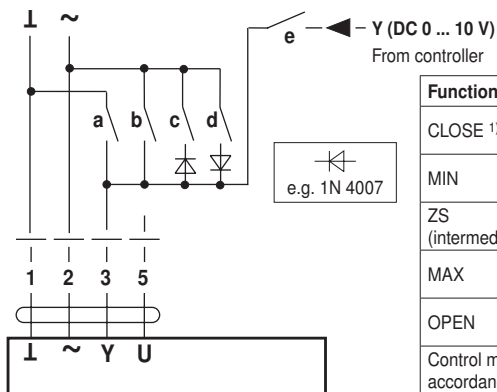

Functions	a	b	c	d	e
CLOSE ¹⁾					
MIN					
ZS (intermediate position)					
MAX					
OPEN					
Control mode in accordance with Y					

Override control and limiting with AC 24 V with rotary switch

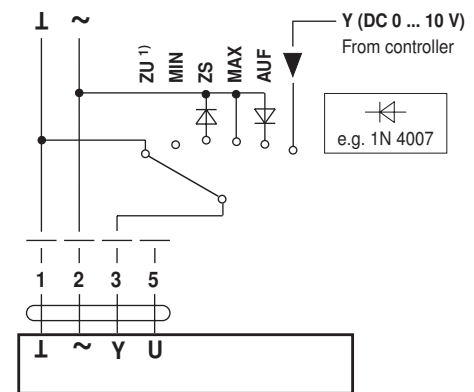

¹⁾ Caution ! This function is only guaranteed if the start point of the operating range is defined as min. 0.6 V

3-point control

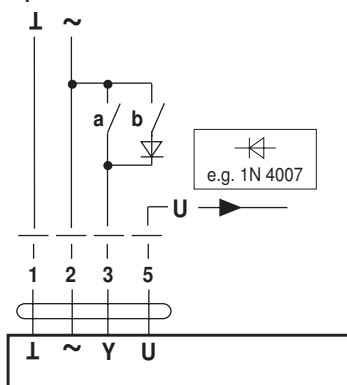

		Direction of rotation switch	
a	b	1	0
		stop	stop

Open-close control

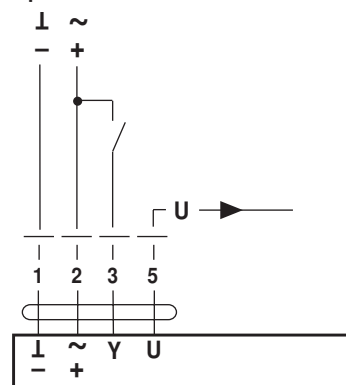

Dimensions [mm]

Dimensional drawings

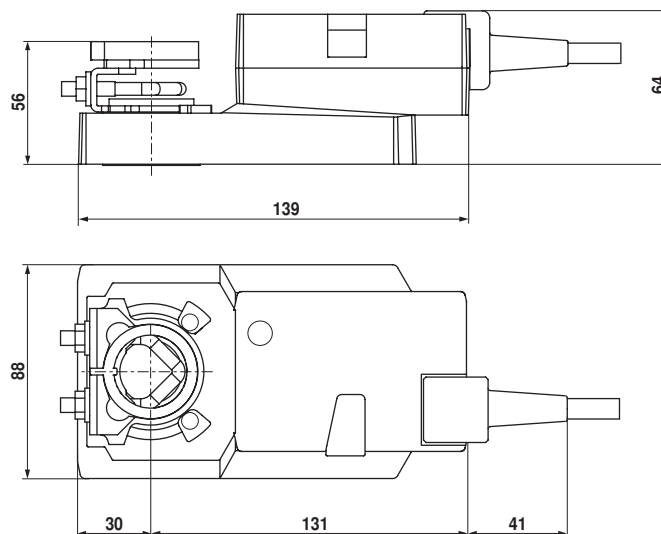

Damper spindle	Length			
	≥48	10 ... 20 ¹⁾	≥10	≤20
	≥20	10 ... 20 ¹⁾	≥10	≤20

¹⁾ CrNi (INOX) 12 ... 20

Operating controls and indicators

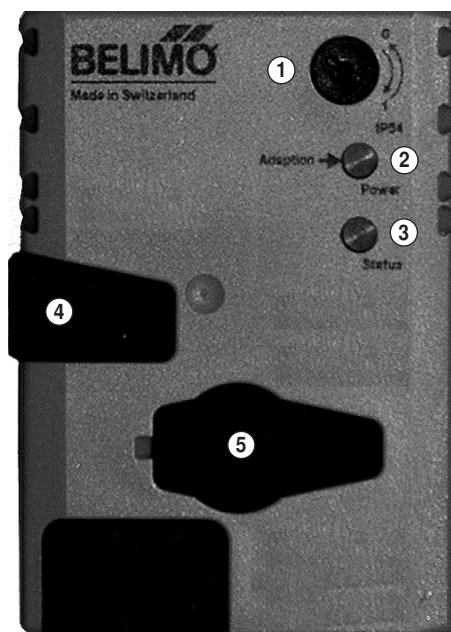

① Direction of rotation switch

Switching over: Direction of rotation changes

② Pushbutton and green LED display

Off: No voltage supply or malfunction

On: Operation

Press button: Switches on angle of rotation adaption followed by standard operation

③ Pushbutton and yellow LED display

Off: Standard operation

On: Adaption or synchronising process active

Press button: No function

④ Gear disengagement switch

Press button: Gear disengaged, motor stops, manual operation possible

Release button: Gear engaged, synchronisation starts, followed by standard operation

⑤ Service plug



For connecting parameterising and service tools

Check voltage supply connection

- a) ② Off and ③ On } Check the supply connections.
 b) ② Blinking and ③ Blinking } Possibly $\underline{\text{L}}$ and $\underline{\text{N}}$ are swapped over.

70214-00003.D

1

			
	10 ... 20	≥10	≤20
CrNi (INOX)	12 ... 20	≥10	≤20

2

3

4

9 Nm
CrNi (INOX) 15 Nm

1 mm

5

Z-PI

65°

≥20

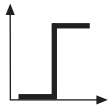
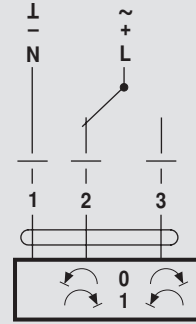
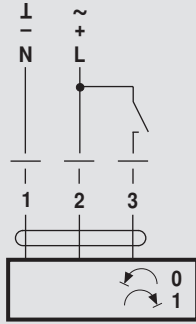

AC 24 V / DC 24 V

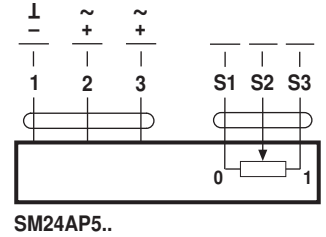
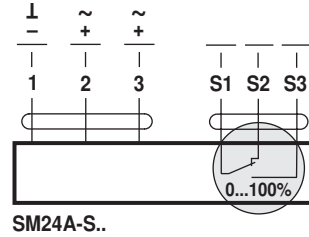
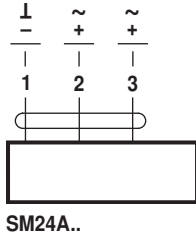

AC 100 ... 240 V ⚠

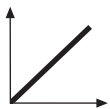
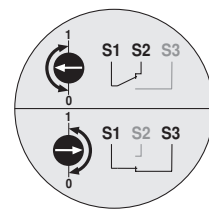
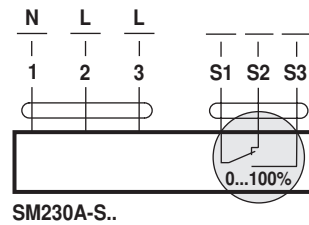
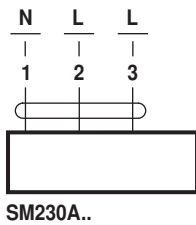

AC 24 V / DC 24 V

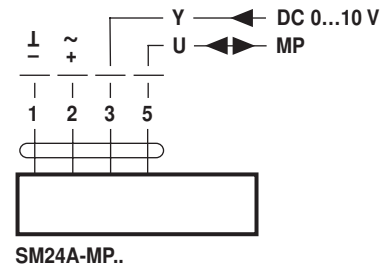
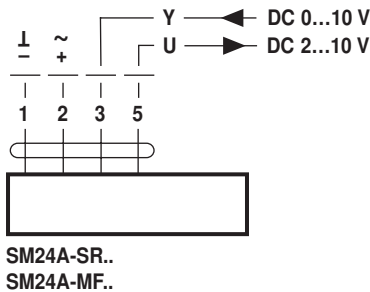

AC 100 ... 240 V ⚠

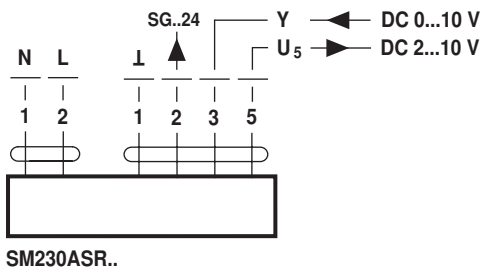

AC 24 V / DC 24 V
(SM24A-V / VR..)

