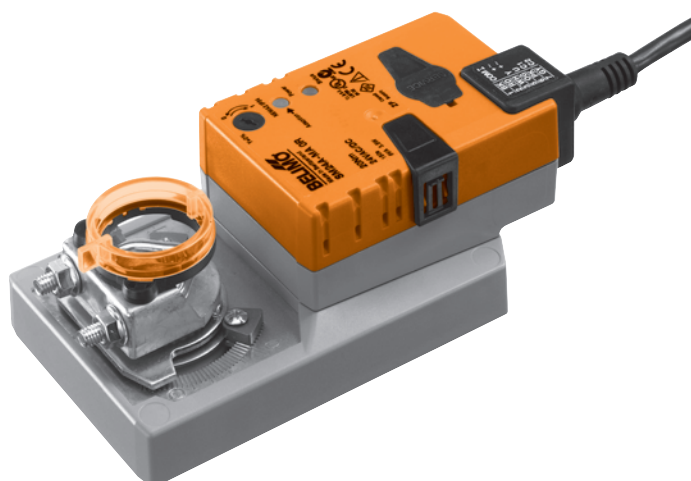

Communication-capable damper actuator for adjusting air dampers in ventilation and air conditioning systems in buildings

- Air damper size up to approx. 4 m²
- Torque 20 Nm
- Nominal voltage AC/DC 24 V
- Control modulating 0 ... 135 Ω
- Position feedback DC 2 ... 10 V or variable

Technical data
Electrical data

Nominal voltage	AC 24 V, 50/60 Hz / DC 24 V
Power supply range	AC 19.2 ... 28.8 V / DC 21.6 ... 28.8 V
Power consumption	3.5 W at nominal torque
In operation	1.25 W
At rest	6 VA
For wire sizing	
Connection	Cable 1 m, 4 x 0,75 mm ²

Functional data	Factory settings	Variable	Settings
Torque (nominal torque)	Min. 20 Nm at nominal voltage	25%, 50%, 75% reduced
Control	0 ... 135 Ω (for controllers: Honeywell, JCI, Sauter)		
Position feedback (measuring voltage U)	DC 2 ... 10 V, max. 0.5 mA	Start point DC 0,5 ... 8 V End point DC 2,5 ... 10 V
Uni-rotation	±5%		
Direction of rotation	Can be selected with 0 / 1		
Direction of motion at Y = 0 V	In switch position 0 ↺ or 1 ↻	Electronically reversible
Manual override	Disengaging the gearing latch by means of a pushbutton, self-resetting		
Angle of rotation	Max. 95° \sphericalangle, can be limited at both ends with mechanical adjustable end stops		
Running time	150 s / 90° \sphericalangle	86 ... 346 s
Automatic adjustment of running time, operating range and measuring signal U to match the mechanical angle of rotation	Manual triggering of this adaption by pressing the button «Adaption» or with the PC-Tool	Automatic adaption whenever the supply voltage is switched on, or manual triggering
Override control	MAX (maximum position) = 100% MIN (minimum position) = 0%	MAX = (MIN + 30° \sphericalangle) ... 100% MIN = 0% ... (MAX - 30° \sphericalangle)
Sound power level	Max. 45 dB (A)	With a running time of 86 s = 45 dB (A) 346 s < 35 dB (A)	
Position indication	Mechanical, plug-on		

Safety

Protection class	III Safety extra-low voltage
Degree of protection	IP54 in all mounting positions
EMC	CE according to 2004/108/EC
Mode of operation	Type 1 (to EN 60730-1)
Rated impulse voltage	0.8 kV (to EN 60730-1)
Control pollution degree	3 (in acc. with EN 60730-1)
Ambient temperature range	-30 ... +50 °C
Non-operating temperature	-40 ... +80 °C
Ambient humidity range	95% r.H., non-condensating (to EN 60730-1)
Maintenance	Maintenance-free

Dimensions/weight

Dimensions	See «Dimensions» on page 4
Weight	Approx. 910 g





Safety notes



- The damper actuator is not allowed to be used outside the specified field of application, especially in aircraft or in any other airborne means of transport.
- It may only be installed by suitably trained personnel.
All applicable legal or institutional installation regulations must be complied with.
- The device may only be opened at the manufacturer's site. It does not contain any parts that can be replaced or repaired by the user.
- The cable is not allowed to be removed from the unit.
- When calculating the torque required, the specifications supplied by the damper manufacturers concerning the cross section, design and installation site, and the air flow conditions must be observed.
- The device contains electrical and electronic components and is not allowed to be disposed of as household refuse. All locally valid regulations and requirements must be observed.

Product features

Mode of operation	The actuator is controlled with a standard modulating signal of 0 ... 135 Ω and travels to the position defined by the control signal. Measuring voltage U serves for the electrical display of the damper position 0 ... 100% and as slave control signal for other actuators.
Parameterisable actuators	The factory settings cover the most common applications. The output signal and other parameters can be altered with the MFT-H parameterising device or the BELIMO Service Tool, MFT-P.
Simple direct mounting	Simple direct mounting on the damper spindle with a universal spindle clamp, supplied with an anti-rotation strap to prevent the actuator from rotating.
Manual override	Manual operation with self-resetting pushbutton possible (the gear is disengaged for as long as the button is pressed).
Adjustable angle of rotation	Adjustable angle of rotation with mechanical end stops.
High functional reliability	The actuator is overload-proof, requires no limit switches and automatically stops when the end stop is reached.
Home position	When the supply voltage is switched on for the first time, i.e. at commissioning or after pressing the «gear disengagement» switch, the actuator travels to the home position.

Pos. direction of rotation switch	Home position
 Y = 0	 Left stop
 Y = 0	 Right stop

The actuator then moves into the position defined by the control signal.

Accessories

	Description	Data sheet
Electrical accessories	Auxiliary switch S..A..	T2 - S..A..
	Feedback potentiometer P..A..	T2 - P..A..
	Manual parameterising device MFT-H	T2 - MFT-H
	PC-Tool MFT-P	T2 - MFT-P
	Position sensor SG..24	T2 - SG..24
	Digital position indication ZAD24	T2 - ZAD24
Mechanical accessories	Various accessories (clamps, shaft extensions etc.)	T2 - Z-SM..A..

Electrical installation

Wiring diagram/example

Note

- Connect via safety isolation transformer.
- Parallel connection of other actuators possible. Note the performance data.

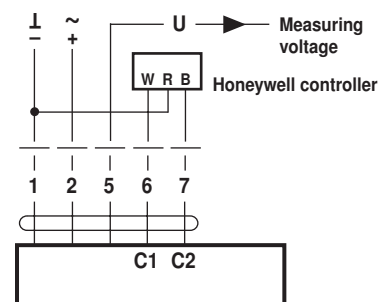
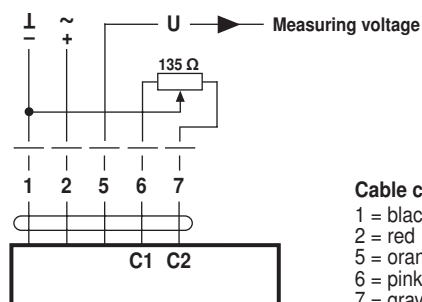

Functions with basic values

Override control with AC 24 V with relay contacts

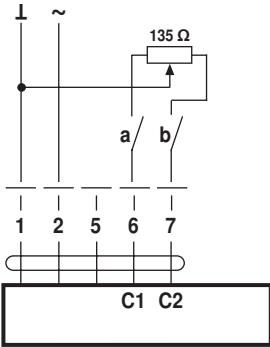

Functions	a	b
0% ↶		
100% ↷		
Control mode in accordance with the position of the potentiometer		

Master/Slave control

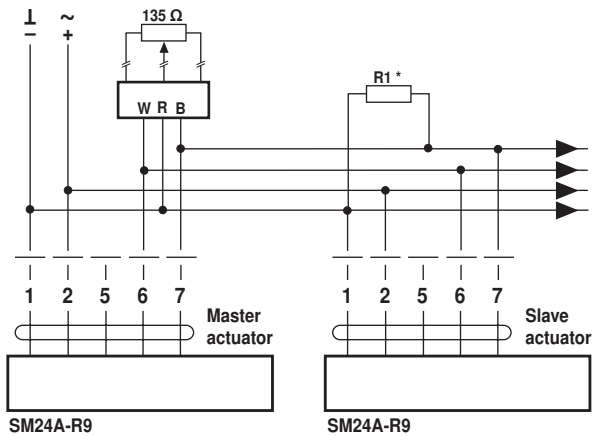
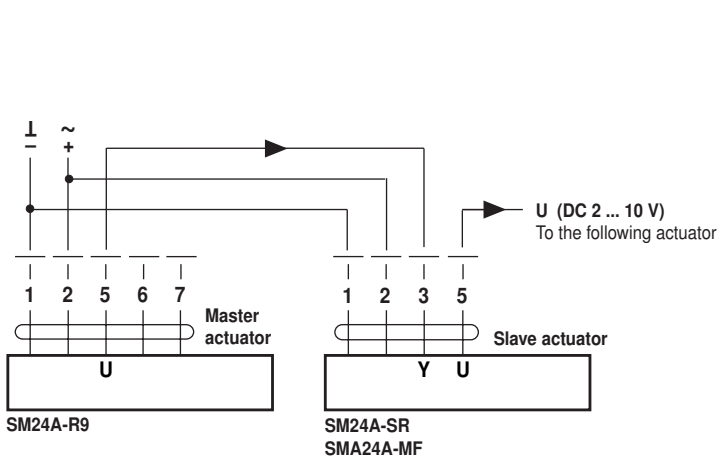

* Note

An additional resistor R1 (between R-B) must be connected in parallel when actuators are operated in parallel. The corresponding value can be seen in the table below.

Number of actuators	2	3	4
Resistor R1 between R-B	1300 Ω	910 Ω	768 Ω

Position indication

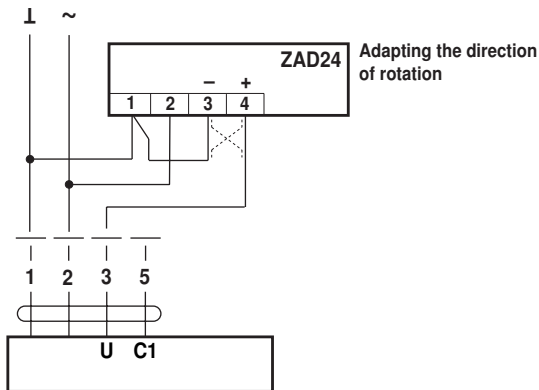

Dimensions [mm]

Dimensional diagrams

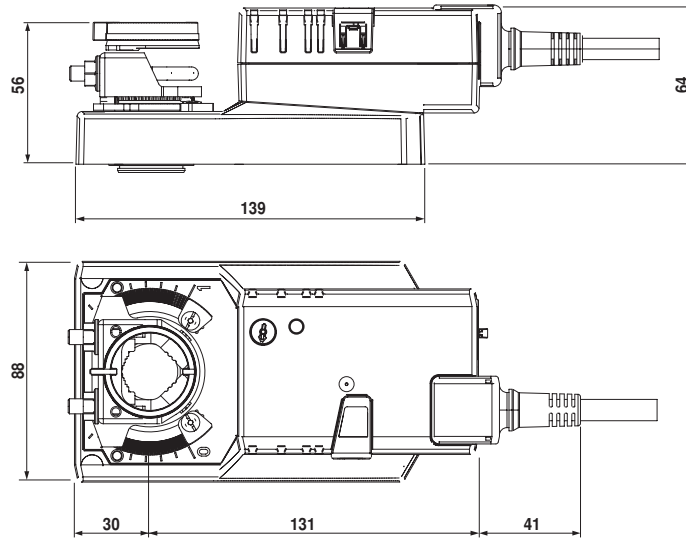

Damper spindle	Length	
Clamp, top	Min. 42	10 ... 20 (26,7) *
Clamp, bottom	Min. 20	10 ... 20

* With K-ENSA as accessory

Operating controls and indicators



① Direction of rotation switch

Switching over: Direction of rotation changes

② Pushbutton and green LED display

Off: No voltage supply or malfunction

Green on: Operation

Press button: Switches on angle of rotation adaption followed by standard operation

③ Pushbutton and yellow LED display

Off: Standard operation

Yellow on: Adaption or synchronising process active

Press button: No function

④ Gear disengagement switch

Press button: Gear disengaged, motor stops, manual operation possible

Release button: Gear engaged, synchronisation starts, followed by standard operation

⑤ Service plug

For connecting parameterising and service tools

70214-00003.C

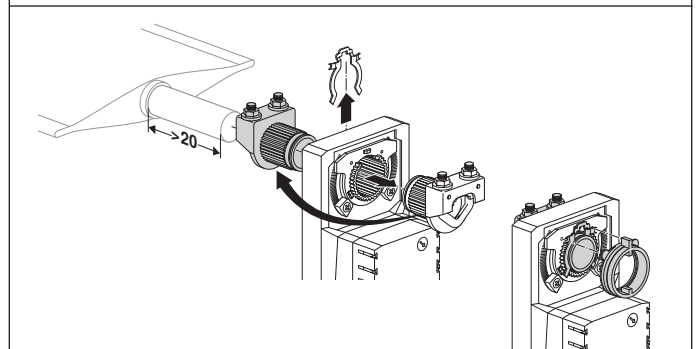
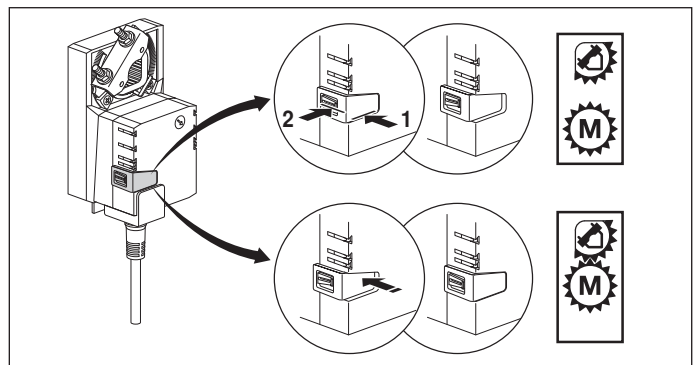
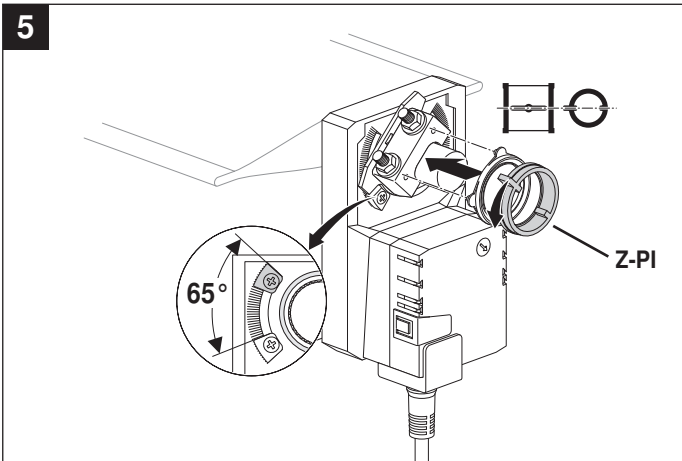
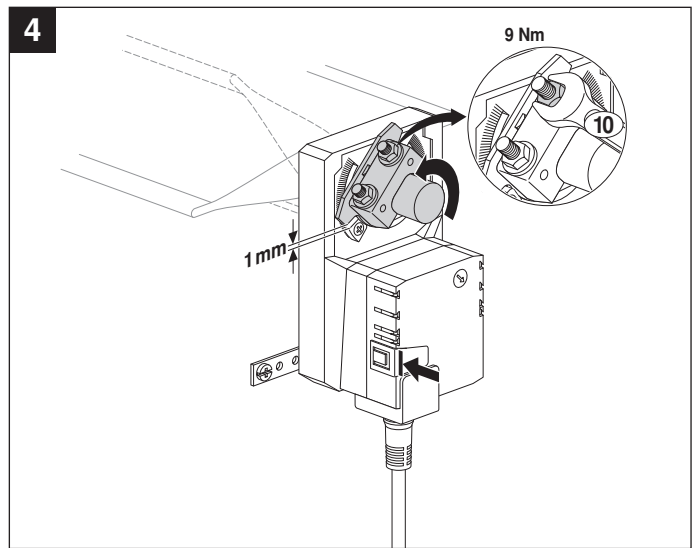
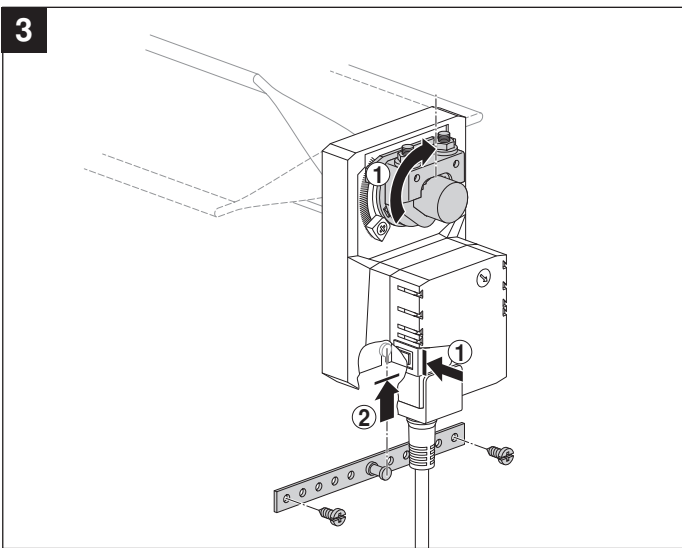
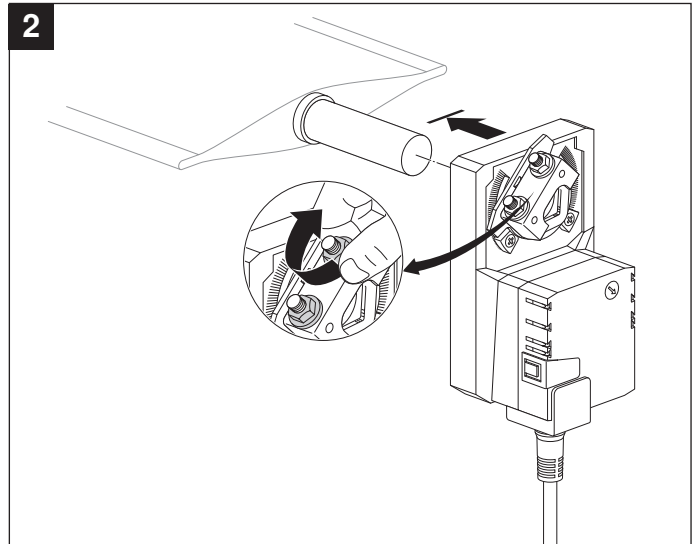
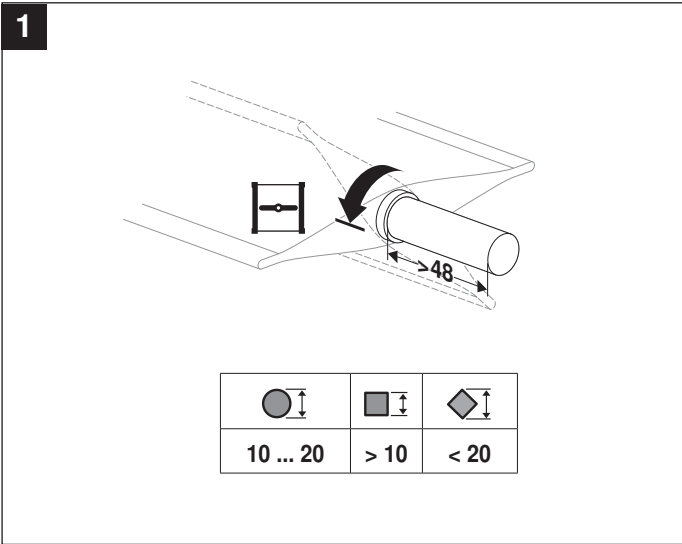

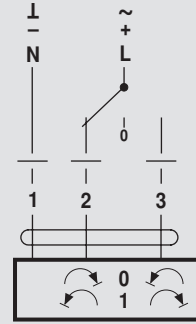
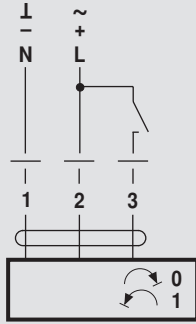

AC 24 V / DC 24 V

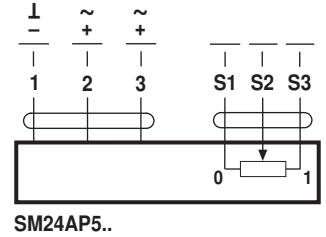
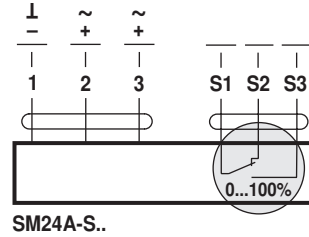
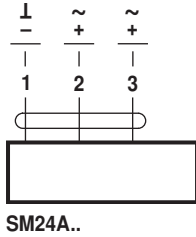

AC 100 ... 240 V ⚠

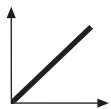
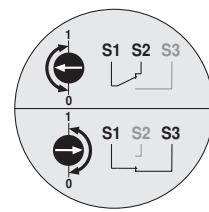
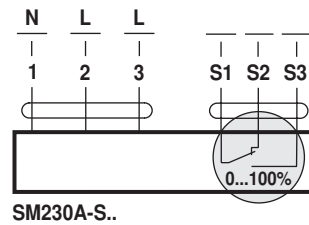
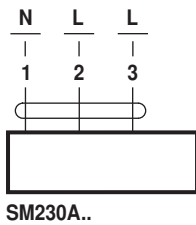

AC 24 V / DC 24 V

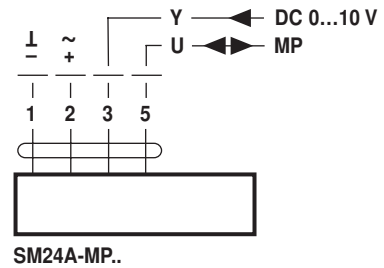
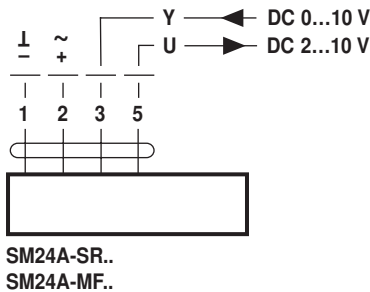

AC 100 ... 240 V ⚠

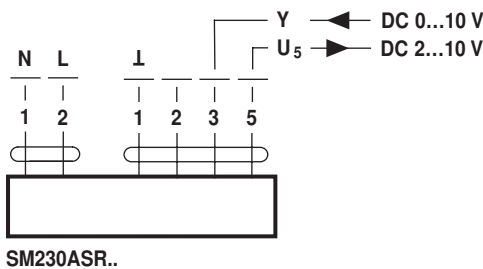

AC 24 V / DC 24 V
(SM24A-V / VR..)

