

Spring return actuator with emergency function for adjusting air dampers in ventilation and air conditioning systems in buildings

- For air dampers up to approx. 6 m<sup>2</sup>
- Torque 30 Nm
- Nominal voltage AC 230 V
- Control: Open-close

**Technical data**

<b>Electrical data</b>	Nominal voltage	AC 230 V, 50/60 Hz
	Nominal voltage range	AC 90 ... 264 V
	Power consumption	In operation 9 W @ nominal torque At rest 4.5 W For wire sizing 21 VA
	Connection	Cable 1 m, 2 x 0.75 mm <sup>2</sup>
<b>Functional data</b>	Torque Motor	Min. 30 Nm @ nominal voltage
	Spring return	Min. 30 Nm
	Direction of rotation	Can be selected by mounting L / R
	Manual override	With hand crank and interlocking switch
	Angle of rotation	Max. 95°↔, can be limited with adjustable mechanical end stop
	Running time Motor	≤75 s (0 ... 30 Nm)
	Spring return	≤20 s @ -20 ... 50 °C / max. 60 s @ -30 °C
	Sound power level Motor	≤55 dB (A)
	Spring return	≤71 dB (A)
	Service life	Min. 60,000 emergency positions
Position indication	Mechanical	
<b>Safety</b>	Protection class	II Totally insulated <input type="checkbox"/>
	Protection mode	IP54 NEMA2, UL Enclosure Type 2
	EMC	CE according to 2004/108/EC
	Low-voltage directive	CE according to 2006/95/EC
	Certification	Certified to IEC/EN 60730-1 and IEC/EN 60730-2-14 cULus according to UL 60730-1A and UL 60730-2-14 and CAN/CSA E60730-1:02
	Mode of operation	Type 1.AA
	Rated impulse voltage	2.5 kV
	Control pollution degree	3
	Ambient temperature	-30 ... +50 °C
	Non-operating temperature	-40 ... +80 °C
Ambient humidity	95% r.h., non-condensating	
Maintenance	Maintenance-free	
<b>Dimensions / Weight</b>	Dimensions	See «Dimensions» on page 3
	Weight	Approx. 4.2 kg

## Safety notes



- The actuator is not allowed to be used outside the specified field of application, especially in aircraft or in any other airborne means of transport.
- **Caution: Power supply voltage!**
- It may only be installed by suitably trained personnel. Any legal regulations or regulations issued by authorities must be observed during assembly.
- The device may only be opened at the manufacturer's site. It does not contain any parts that can be replaced or repaired by the user.
- The cables must not be removed from the device.
- When calculating the required torque, the specifications supplied by the damper manufacturers (cross-section, design, installation site), and the air flow conditions must be observed.
- The device contains electrical and electronic components and is not allowed to be disposed of as household refuse. All locally valid regulations and requirements must be observed.

## Product features

**Mode of operation** The actuator moves the damper to the operating position at the same time as tensioning the return spring. The damper is turned back to the emergency position by spring force if the supply voltage is interrupted.

**Simple direct mounting** Simple direct mounting on the damper spindle with a universal spindle clamp, supplied with an anti-rotation strap to prevent the actuator from rotating.

**Achsstabilisator** Der Klemmbock des Federrücklaufantriebs ist werksseitig mit einem Achsstabilisator für die Stabilisierung der Kombination Klappe, Klappenachse und Antrieb ausgerüstet. Dieser besteht aus zwei Kunststoff-Stützringen und muss je nach Montagesituation und Achsdurchmesser belassen, teilweise oder komplett entfernt werden.

### Langachsmontage:

- Bei Langachsmontage mit einem Achsdurchmesser von 12 bis 20 mm ist der Einsatz des Achsstabilisators notwendig.
- Bei Langachsmontage mit einem Achsdurchmesser von 21 bis 26,7 mm ist der Einsatz des Achsstabilisators nicht notwendig und kann entfernt werden.

### Kurzachsmontage:

- Bei Kurzachsmontage entfällt die Notwendigkeit des Achsstabilisators, er kann entfernt oder – falls es die Achslänge zulässt – im Klemmbock belassen werden.

Weitere Hinweise siehe Montageanleitung.

**Manual override** Manual operation of the damper with the hand crank, locking in any position with the interlocking switch. Unlocking is manual or automatic by applying the operating voltage.

**Adjustable angle of rotation** Adjustable angle of rotation with mechanical end stop.

**High operational reliability** The actuator is overload-proof, requires no limit switches and automatically stops when the end stop is reached.

### Important

The spindle stabiliser must nonetheless be used when the universal mounting bracket is installed on the opposite side of the spindle clamp and with a spindle diameter <20 mm.



## Electrical installation

### Wiring diagram

#### Notes

- Caution: Power supply voltage!
- Parallel connection of other actuators possible. Note the performance data.

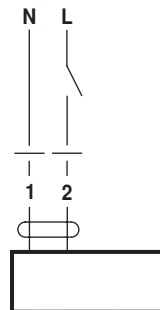

#### Cable colours:

- 1 = blue
- 2 = brown

Accessories

Mechanical accessories

Description

- Position indicator IND-EFB
- Clamp K9-2
- Crank arm KH-EFB
- Crank arm adaptor kit ZG-EFB

Dimensions [mm]

Dimensional drawings

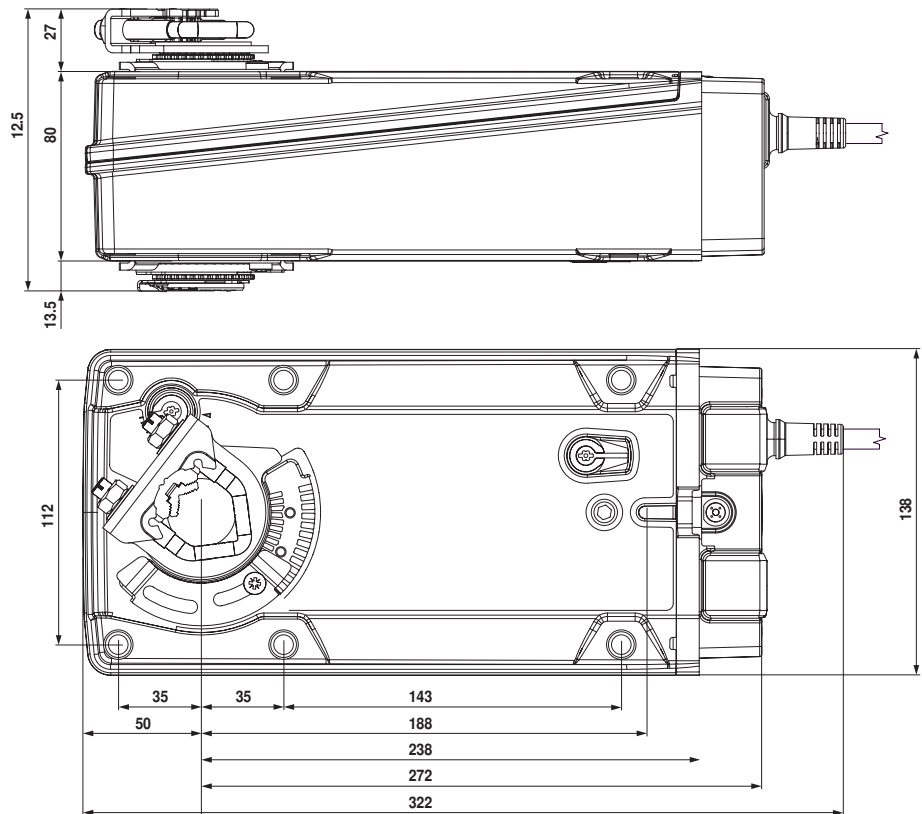

Damper spindle	Length	●	■	◆
	≥117	12 ... 26,7	>12	<25,2
	≥20	12 ... 26,7	>12	<25,2

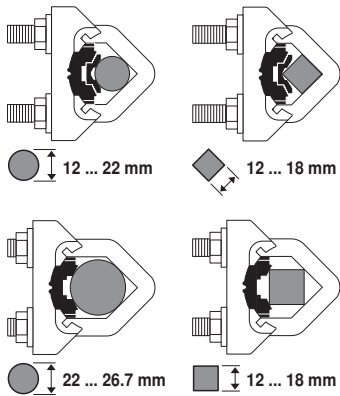

71305-00001.C

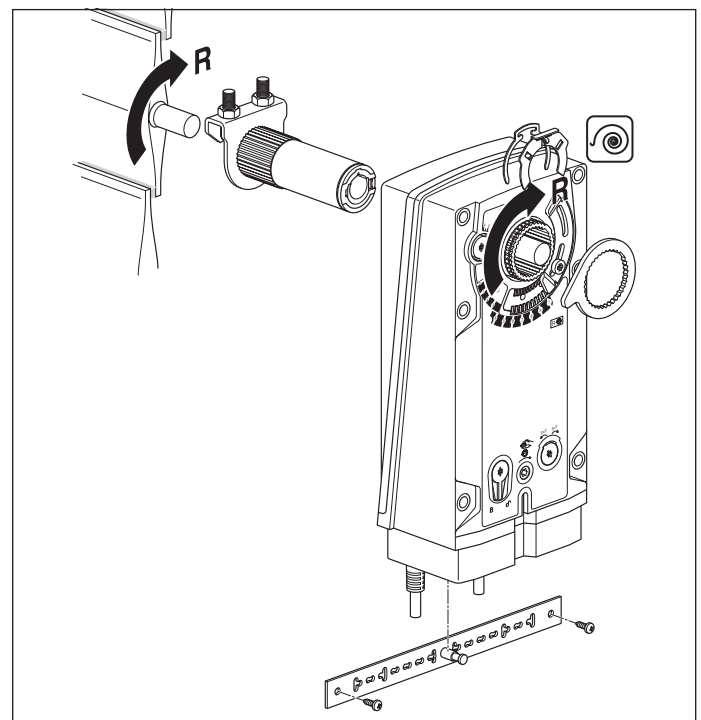
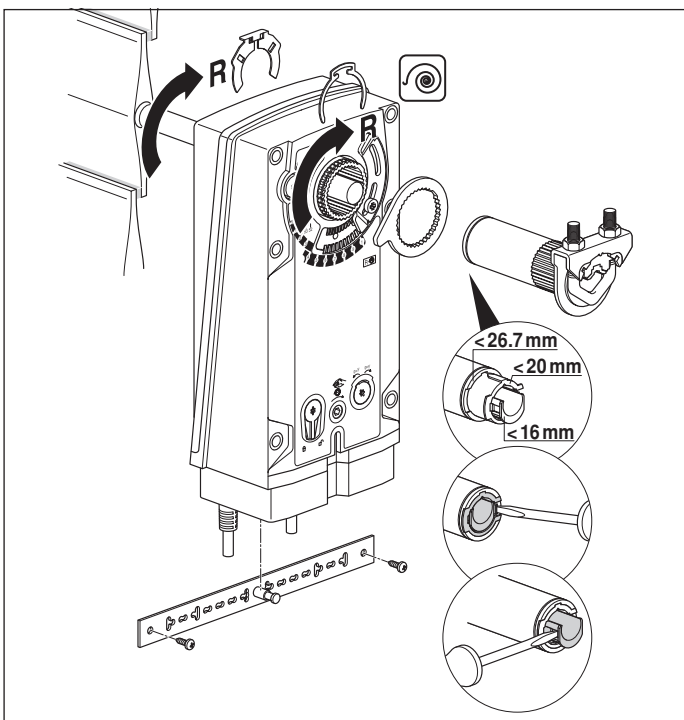
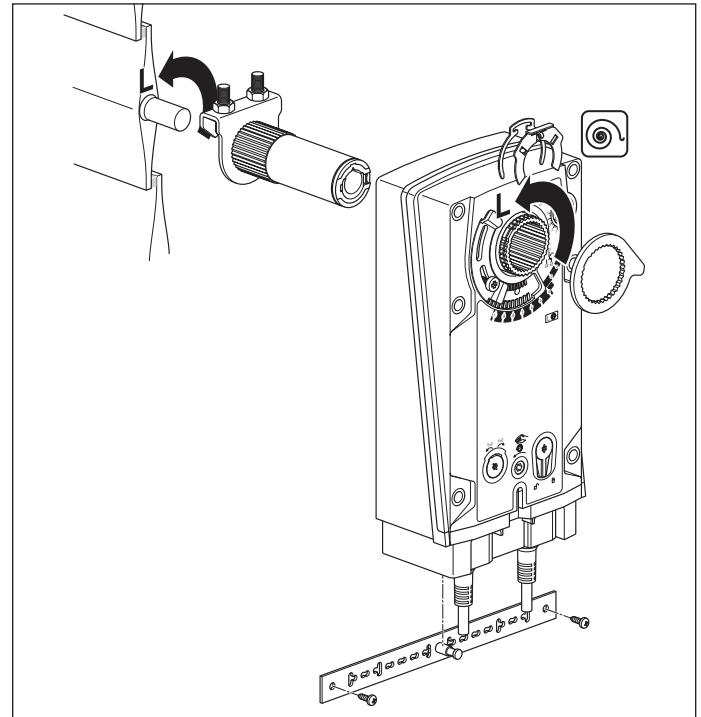
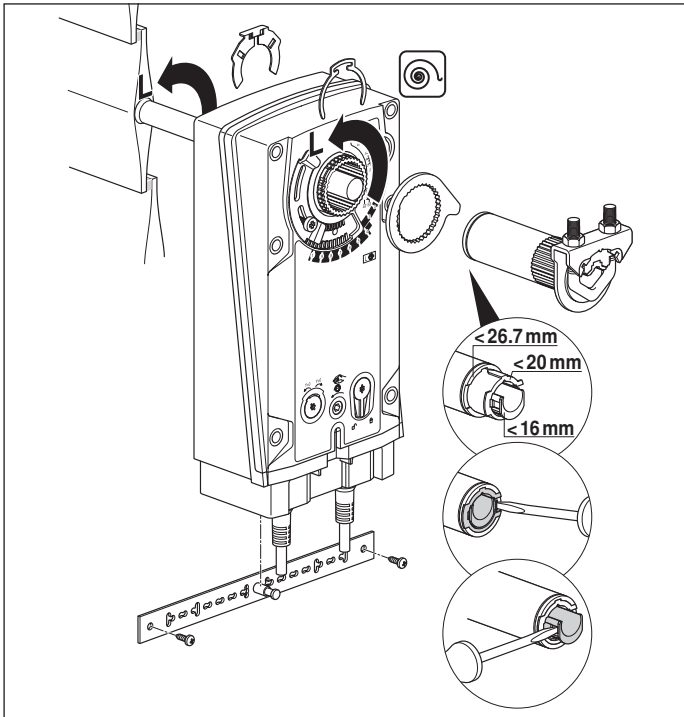
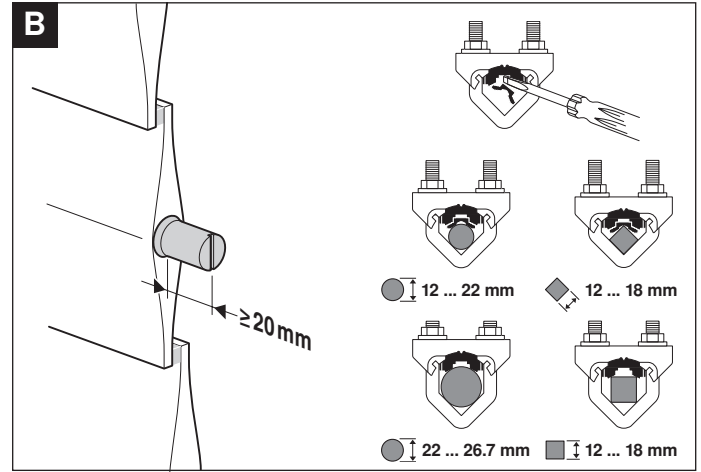
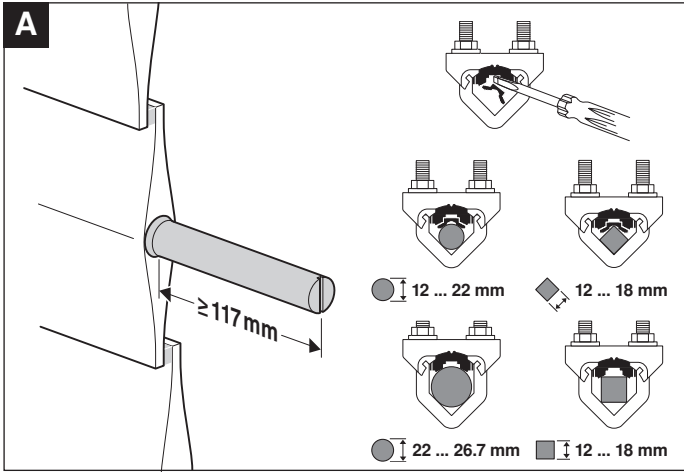

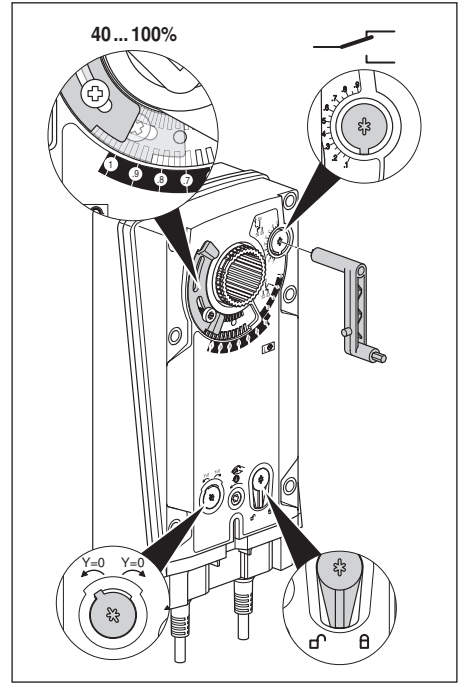
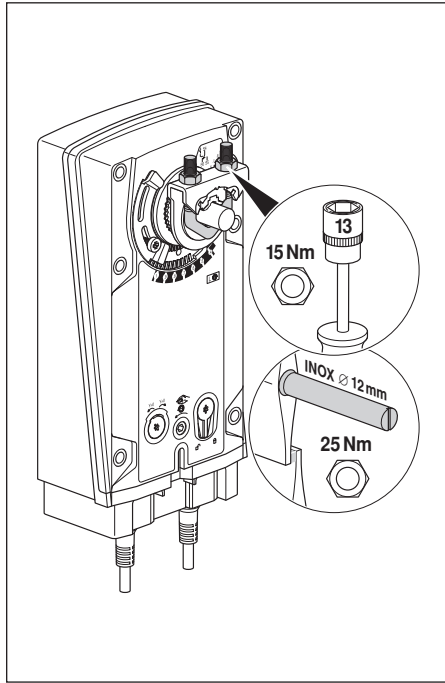
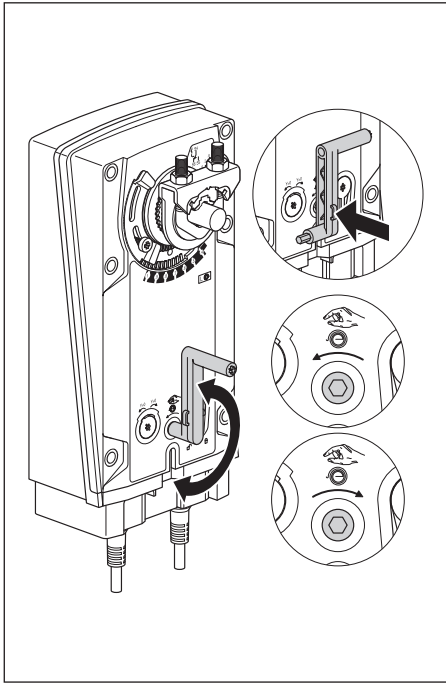

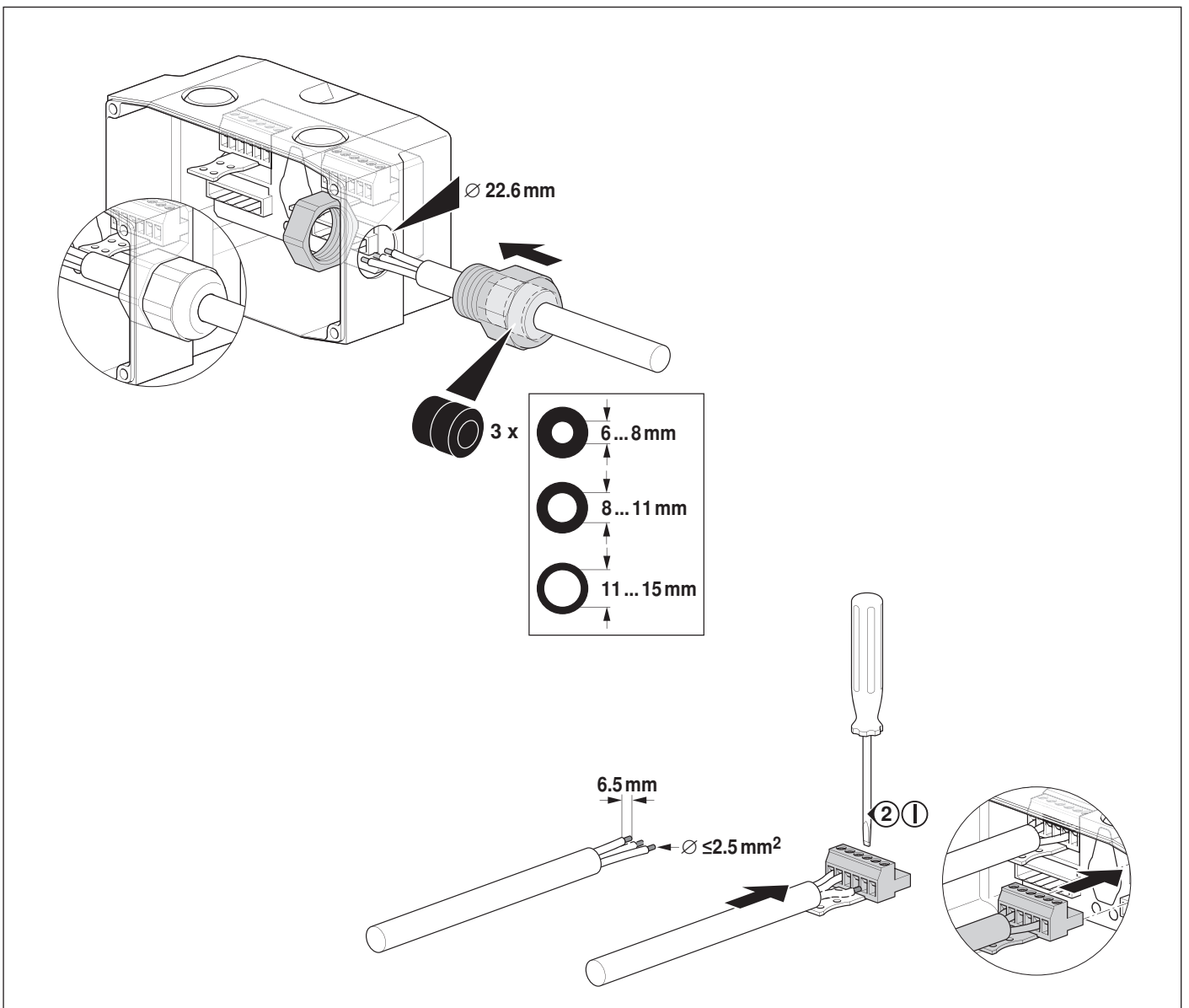
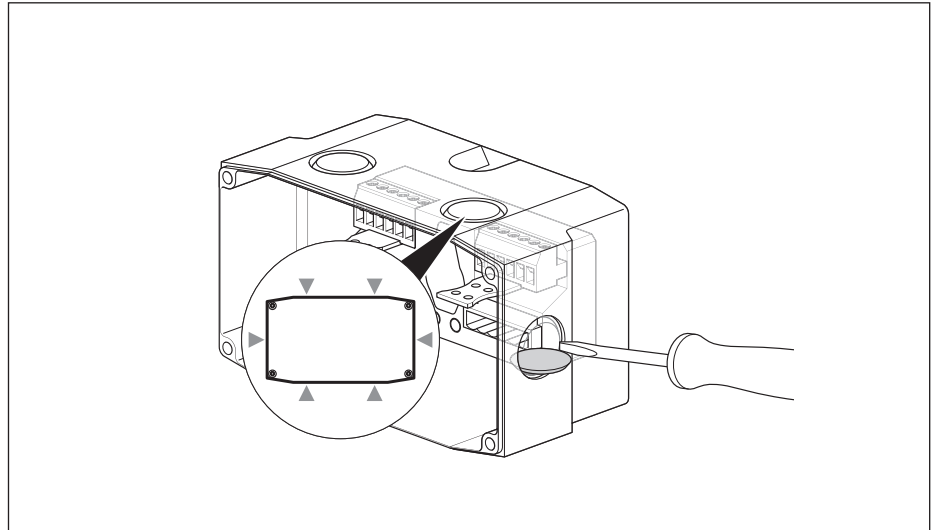
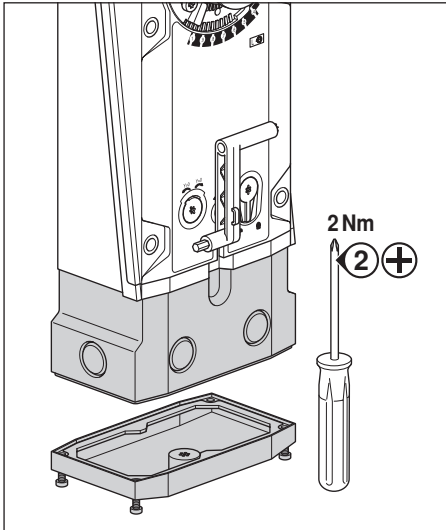

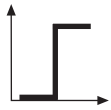

AC 24 V / DC 24 V

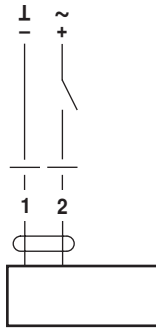

EF24A

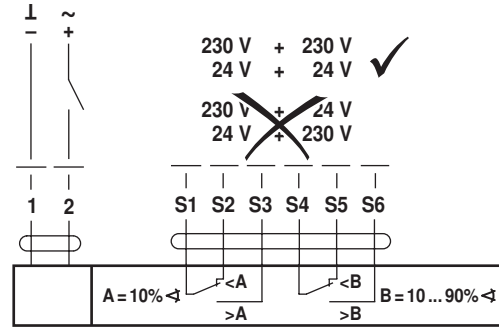

EF24A-S2

230 V + 230 V  
24 V + 24 V ✓  
~~230 V + 24 V~~  
~~24 V + 230 V~~

AC 100 ... 240 V ⚠

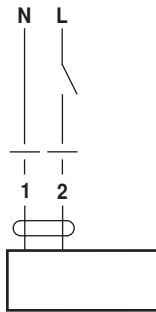

EF230A

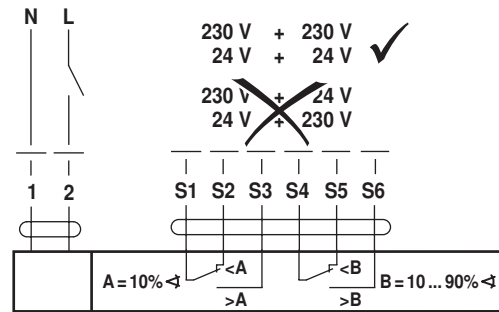

EF230A-S2

230 V + 230 V  
24 V + 24 V ✓  
~~230 V + 24 V~~  
~~24 V + 230 V~~

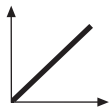

AC 24 V / DC 24 V

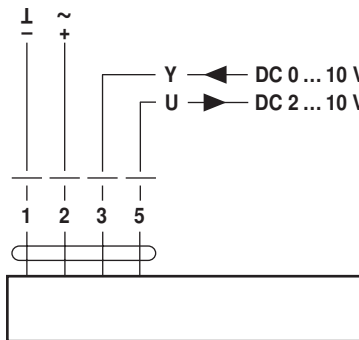

EF24A-SR  
EF24A-MF

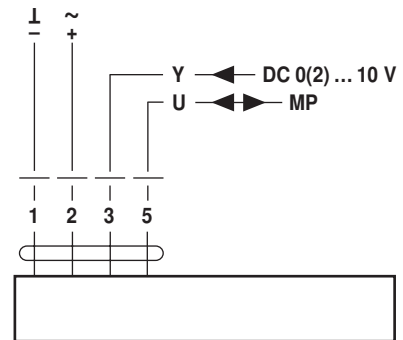

EF24A-MP

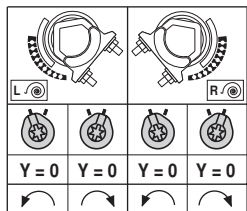

EF24A-SR  
EF24A-SR-S2

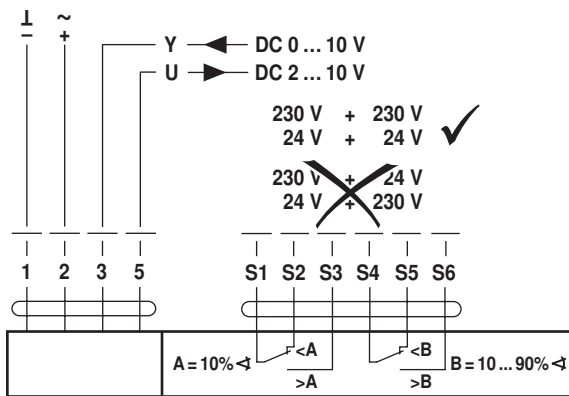

EF24A-SR-S2

230 V + 230 V  
24 V + 24 V ✓  
~~230 V + 24 V~~  
~~24 V + 230 V~~