

Communicative spring return actuator with emergency function for adjusting air dampers in ventilation and air conditioning systems in buildings

- For air dampers up to approx. 6 m²
- Torque 30 Nm
- Nominal voltage AC/DC 24 V
- Control: modulating DC 0 ... 10 V or variable
- Position feedback DC 0 ... 10 V or variable
- Communication via BELIMO MP-Bus
- Conversion of sensor signals

Technical data
Electrical data

Nominal voltage	AC 24 V, 50/60 Hz / DC 24 V
Nominal voltage range	AC 19.2 ... 28.8 V / DC 21.6 ... 28.8 V
Power consumption	In operation 9.5 W @ nominal torque
	At rest 4.5 W
	For wire sizing 16 VA
Connection	Cable 1 m, 4 x 0.75 mm ²
Parallel operation	Yes

Functional data	Factory settings	Variable	Setting
Torque (nominal torque) Motor	Min. 30 Nm @ nominal voltage		
Spring return	Min. 30 Nm		
Control Control signal Y	DC 0 ... 10 V, input impedance 100 kΩ	Open-close, 3-point (only AC), modulating (DC 0 ... 32 V)
Operating range	DC 0.5 ... 10 V	Start point DC 0.5 ... 30 V End point DC 2.5 ... 32 V
Position feedback (measuring voltage U)	DC 0.5 ... 10 V, max. 0.5 mA	Start point DC 0.5 ... 8 V End point DC 2.5 ... 10 V
Position accuracy	±5%		
Direction of rotation Motor	Reversible with switch ↻ / ↺		
Spring return	By mounting		
Direction of rotation Y = 0 V	At switch position 1 ↻ and 0 ↺, respectively	Electronically reversible
Manual override	With hand crank and interlocking switch		
Angle of rotation	Max. 95° ↻, adjustable from 33% in 5% steps (with enclosed angle of rotation limiter)		
Running time Motor	≤150 s / 90° ↻	60 ... 150 s
Spring return	≤20 s @ -20 ... 50°C / max. 60 s @ -30°C		
Automatic adjustment of running time, operating range and measuring signal U to match the mechanical angle of rotation	Manual triggering of the adaption by pressing the «Adaption» button	Automatic adaption whenever the supply voltage is switched on, or manual triggering
Override control	MAX (maximum position) = 100% MIN (minimum position) = 0% ZS (intermediate position, only AC) = 50%	MAX = (MIN + 32%) ... 100% MIN = 0% ... (MAX - 32%) ZS = MIN ... MAX
Sound power level Motor	≤45 dB (A) @ 150 s running time		
Spring return	≤71 dB (A)		
Service life	Min. 60,000 emergency positions		
Position indication	Mechanical		
Safety			
Protection class	III Extra low voltage UL Class 2 Supply		
Degree of protection	IP54 NEMA2, UL Enclosure Type 2		
EMC	CE according to 2004/108/EC		

Technical data	(Continued)
Certification	Certified to IEC/EN 60730-1 and IEC/EN 60730-2-14 cULus according to UL 60730-1A and UL 60730-2-14 and CAN/CSA E60730-1:02
Mode of operation	Type 1.AA
Rated impulse voltage	0.8 kV
Control pollution degree	3
Ambient temperature	-30 ... +50 °C
Non-operating temperature	-40 ... +80 °C
Ambient humidity	95% r.h., non-condensating
Maintenance	Maintenance-free
Dimensions / Weight	
Dimensions	See «Dimensions» on page 6
Weight	Approx. 4.3 kg

Safety notes



- The actuator is not allowed to be used outside the specified field of application, especially in aircraft or in any other airborne means of transport.
- It may only be installed by suitably trained personnel. Any legal regulations or regulations issued by authorities must be observed during assembly.
- The device may only be opened at the manufacturer's site. It does not contain any parts that can be replaced or repaired by the user.
- The cable must not be removed from the device.
- The device contains electrical and electronic components and is not allowed to be disposed of as household refuse. All locally valid regulations and requirements must be observed.

Product features

Mode of operation	<p><i>Conventional operation:</i> The actuator is controlled with a standard modulating signal of DC 0 ... 10 V and travels to the position defined by the control signal. Measuring voltage U serves for the electrical display of the damper position 0 ... 100% and as slave control signal for other actuators.</p> <p><i>Operation on the MP-Bus:</i> The actuator receives its digital positioning signal from the higher level controller via the MP-Bus and travels to the position defined. Connection U serves as communication interface and does not supply an analogue measuring voltage.</p>
Converter for sensors	Connection option for a sensor (passive or active sensor or switching contact). The MP actuator serves as an analogue/digital converter for the transmission of the sensor signal via MP-Bus to the higher level system.
Parameterisable actuators	The factory settings cover the most common applications. Input and output signals and other parameters can be altered with the BELIMO Service tool MFT-P or the adjustment and diagnostic tool ZTH-GEN.
Simple direct mounting	Simple direct mounting on the damper spindle with a universal spindle clamp, supplied with an anti-rotation strap to prevent the actuator from rotating.
Spindle stabiliser	<p>The spindle clamp of the spring-return actuator is equipped ex-works with a spindle stabiliser for stabilising the combination of damper, damper spindle and actuator. This is comprised of two plastic support rings and, depending on the installation situation and the spindle diameter, must be left in place or partially or completely removed.</p> <p>Long spindle installation:</p> <ul style="list-style-type: none"> • The use of the spindle stabiliser is necessary with long spindle installation with a spindle diameter of 12 to 20 mm. • The use of the spindle stabiliser is not necessary with long spindle installation with a spindle diameter of 21 to 26.7 mm, and it can be removed. <p>Short axis installation:</p> <ul style="list-style-type: none"> • The necessity of the spindle stabiliser does not apply with short spindle installation; it can be removed or – if the length of the spindle permits it – left in the spindle clamp. <p>For additional information, see the Installation instructions.</p>

Important

The spindle stabiliser must nonetheless be used when the universal mounting bracket is installed on the opposite side of the spindle clamp and with a spindle diameter <20 mm.



Product features

(Continued)

High operational reliability

The actuator is overload-proof, requires no limit switches and automatically stops when the end stop is reached.

Home position

When the supply voltage is switched on, the actuator automatically detects its emergency position (zero initialisation). This process, which takes place with the actuator stationary, lasts <15 s.

Accessories

	Description
Electrical accessories	BELIMO Service tool MFT-P
	Adjustment and diagnostic tool ZTH-GEN
Mechanical accessories	Position indicator IND-EFB
	Clamp K9-2
	Crank arm KH-EFB
	Crank arm adaptor kit ZG-EFB

Electrical installation

Wiring diagrams

Notes

- Connect via safety isolation transformer.
- Other actuators can be connected in parallel. Note performance data for supply.



Conventional operation

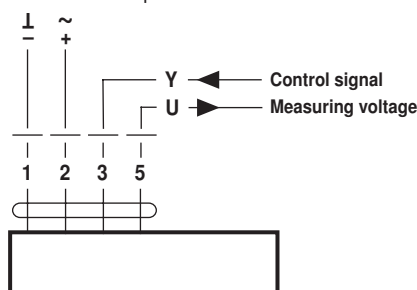

Operation on the MP-Bus

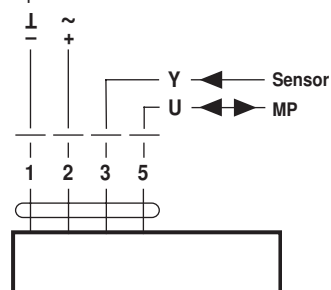

Cable colours:
 1 = black
 2 = red
 3 = white
 5 = orange

Functions when operated on MP-Bus

Connection on the MP-Bus

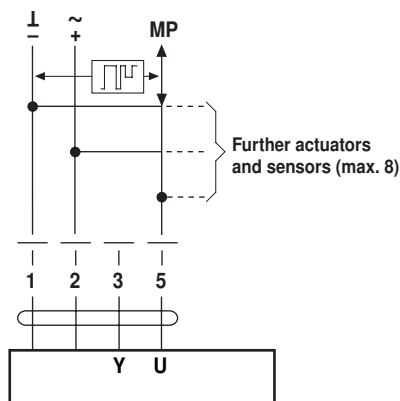

Supply and communication

- in one and the same 3-wire cable
- no shielding or twisting necessary
- no terminating resistors required

Power topology

There are no restrictions for the network topology (star, ring, tree or hybrid forms are permitted).

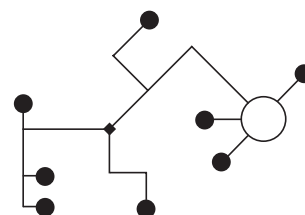

Connection of active sensors

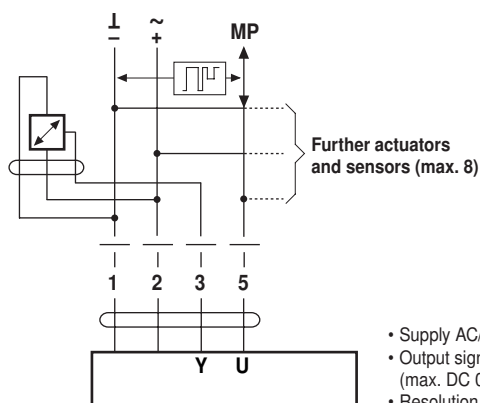

- Supply AC/DC 24 V
- Output signal DC 0 ... 10 V (max. DC 0 ... 32 V)
- Resolution 30 mV

Connection of external switching contact

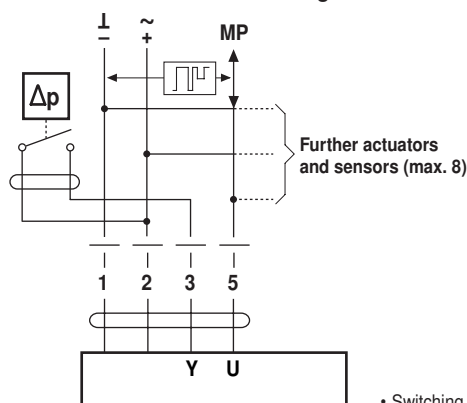

- Switching current 16 mA @ 24 V

Functions when operated on MP-Bus (Continued)

Connection of passive sensors

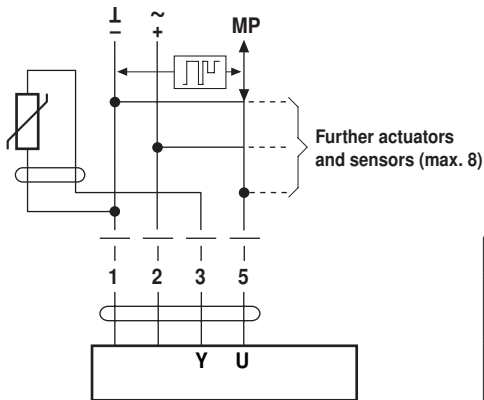

Sensor	Temperature range	Resistance range	Resolution
Ni1000	-28 ... +98 °C	850 ... 1600 Ω	1 Ω
PT1000	-35 ... +155 °C	850 ... 1600 Ω	1 Ω
NTC	-10 ... +160 °C (depending on type)	200 Ω ... 50 kΩ	1 Ω

Functions with basic values

Override control with AC 24 V with relay contacts

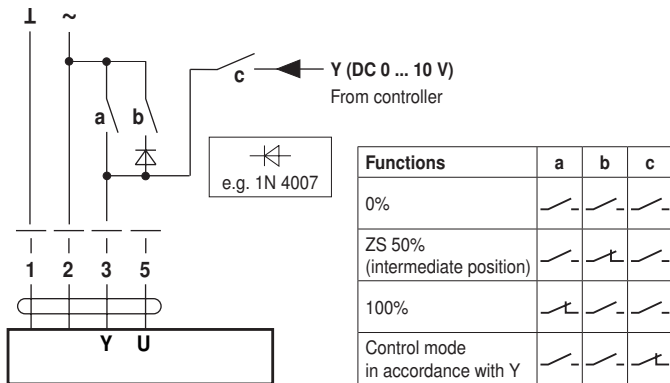

Remote control 0 ... 100 %

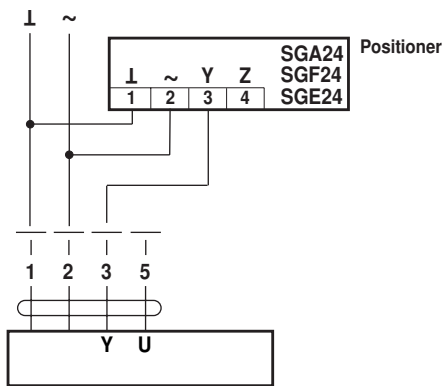

Minimum limit

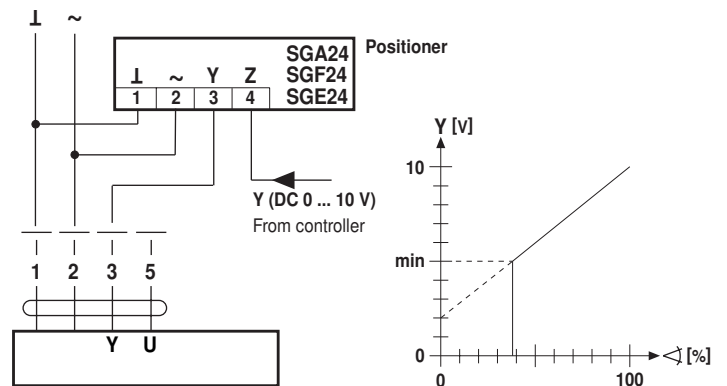

Master/Slave control (position-dependent)

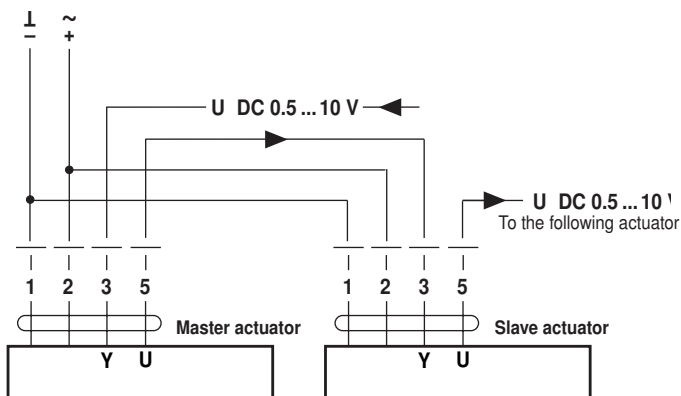

Control with 4 ... 20 mA via external resistance

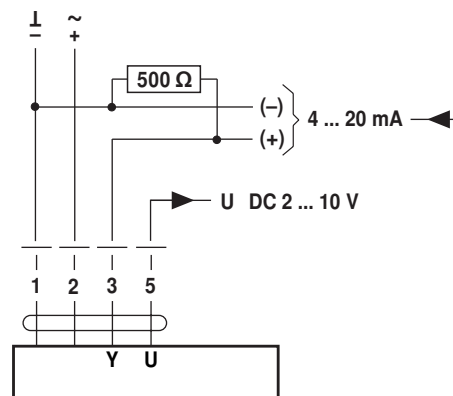

The 500 Ω-resistor converts the 4 ... 20 mA current signal to a voltage signal DC 2 ... 10 V. Operating range adjusted on DC 2...10 V

Functions with basic values

(Continued)

Position indication

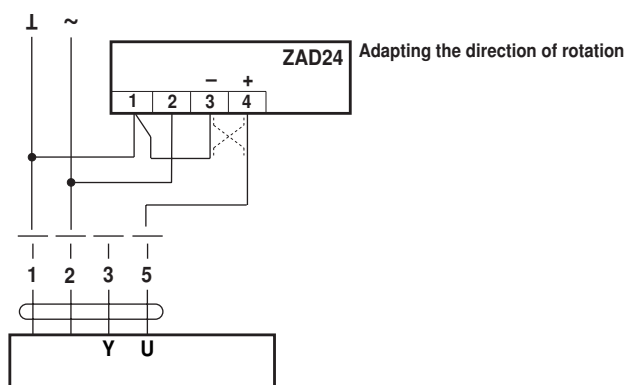

Functional check

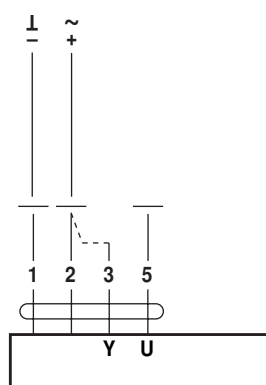

Procedure

- Apply 24 V to connection 1 and 2
- Disconnect connection 3:
 - For direction of rotation 0: Actuator turns in the direction of ↻
 - For direction of rotation 1: Actuator turns in the direction of ↻
- Short circuit connections 2 and 3:
 - Actuator runs in the opposite direction

Functions for actuators with specific parameters

Override control and limiting with AC 24 V with relay contacts

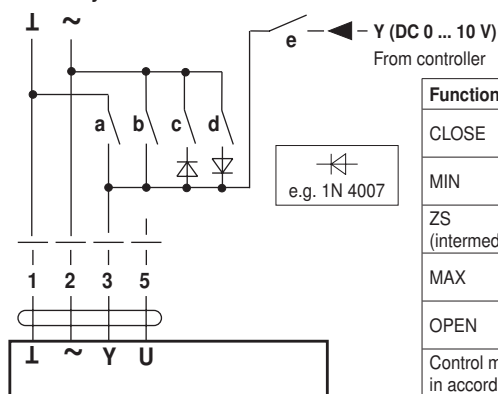

Functions	a	b	c	d	e
CLOSE	↘	↘	↘	↘	↘
MIN	↘	↘	↘	↘	↘
ZS (intermediate position)	↘	↘	↘	↘	↘
MAX	↘	↘	↘	↘	↘
OPEN	↘	↘	↘	↘	↘
Control mode in accordance with Y	↘	↘	↘	↘	↘

Override control and limiting with AC 24 V with rotary switch

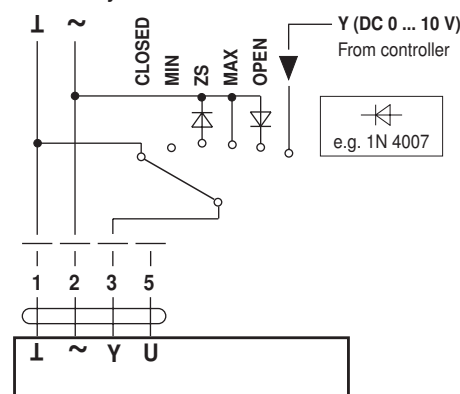

3-point control

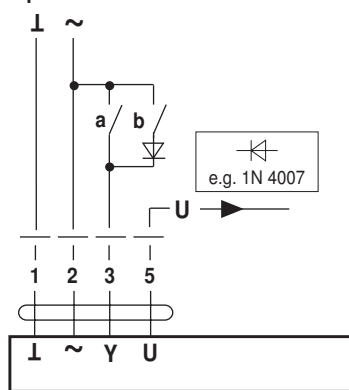

a (Y1)	b (Y2)	↻	↻	↻	↻
↘	↘	↻	↻	↻	↻
↘	↘	stop	stop	stop	stop
↘	↘	↻	↻	↻	↻
↘	↘	↻	↻	↻	↻

Open-close control

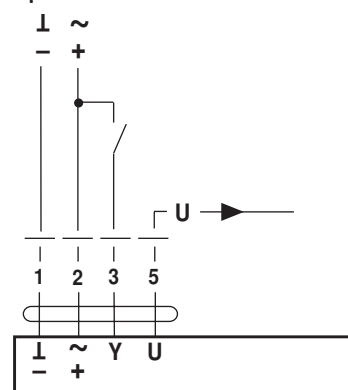

Operating controls and indicators

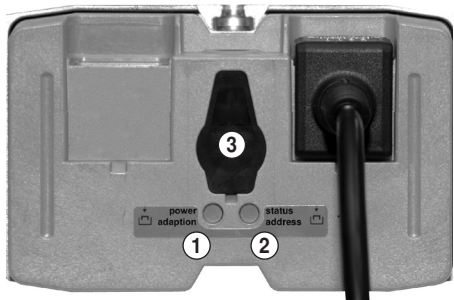

- ① **Pushbutton and green LED display**
 Off: No voltage supply or malfunction
 On: Operation
 Press button: Switches on angle of rotation adaption followed by standard operation
- ② **Pushbutton and yellow LED display**
 Off: Standard operation without MP bus
 Flickering: MP communication active
 On: Adaption or synchronising process active
 Blinking: Addressing request sent to MP master
 Press button: No function
- ③ **Service plug**
 For connecting parameterising and service tools

Check voltage supply connection

- a) ① Off and ② On } Check the supply connections.
- b) ① Blinking and ② Blinking } Possibly \perp and ∇ are swapped over.

Operating controls The hand crank, interlocking switch and direction of rotation switch are provided on both sides.

Dimensions [mm]

Dimensional drawings

Damper spindle	Length	●	■	◆
	≥117	12 ... 26,7	>12	<25,2
	≥20	12 ... 26,7	>12	<25,2

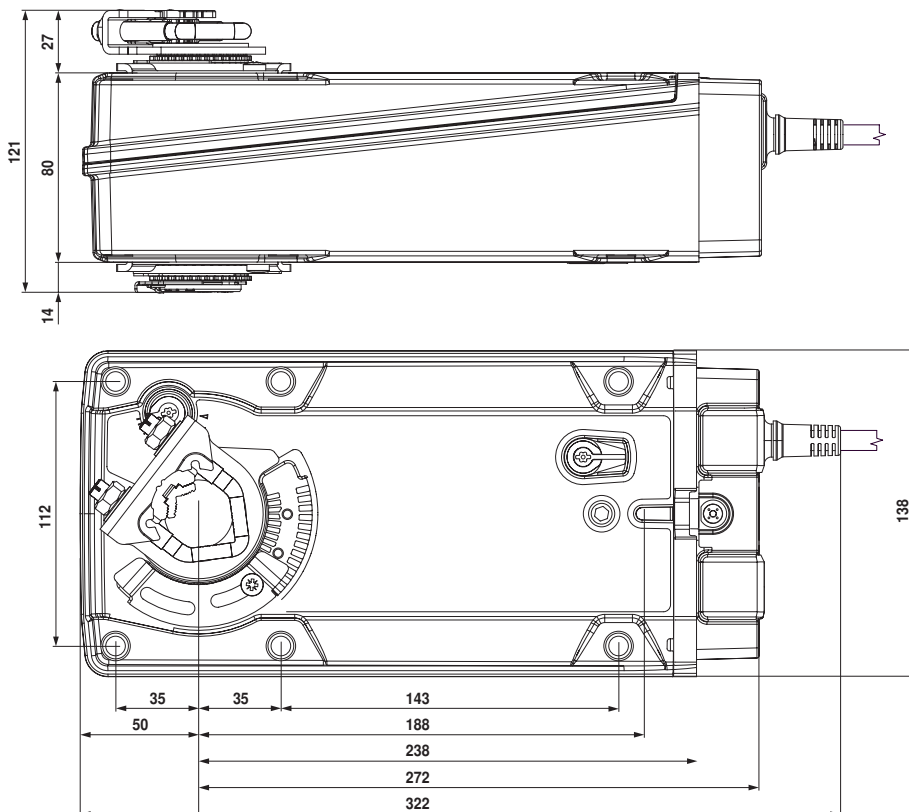
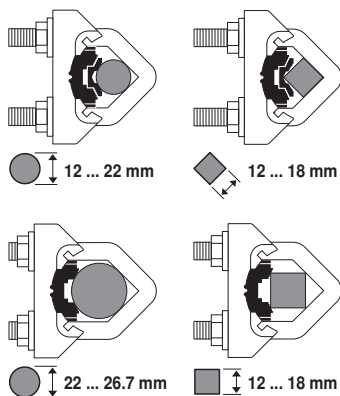

71305-00001.C

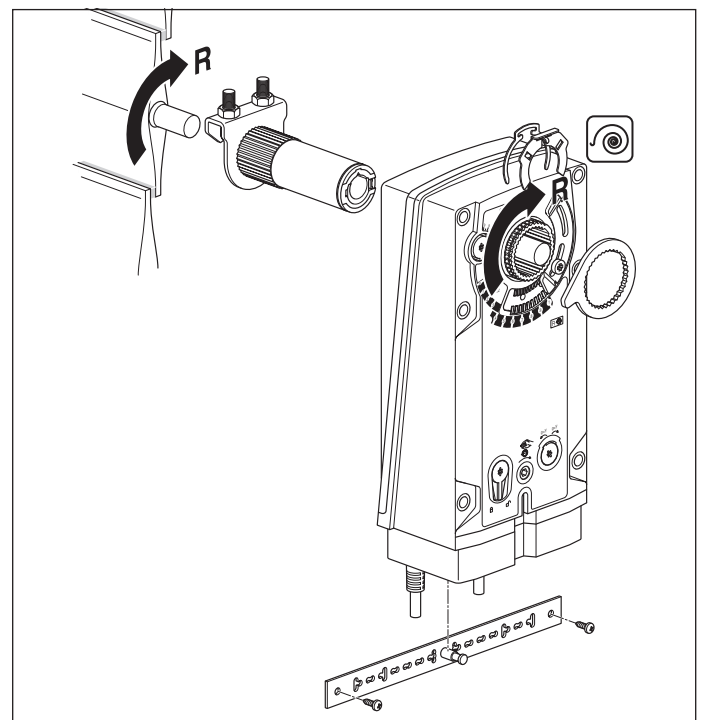
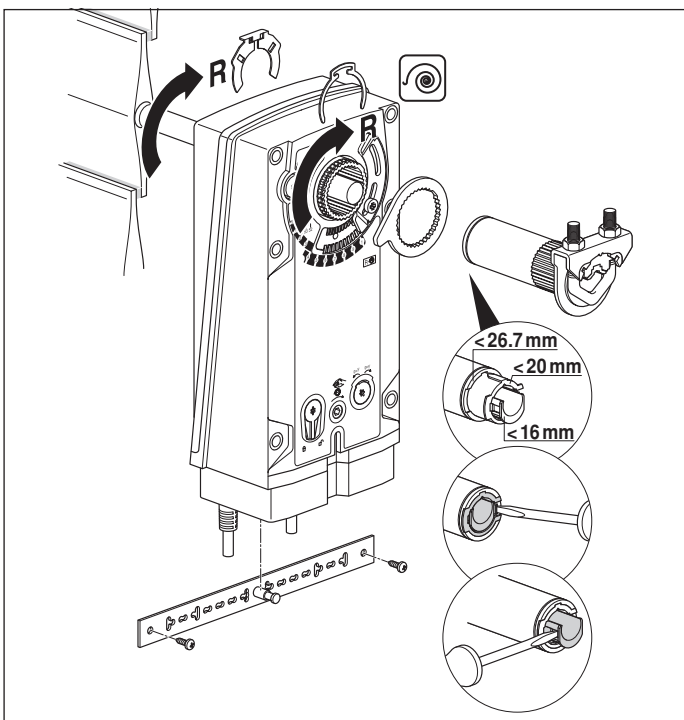
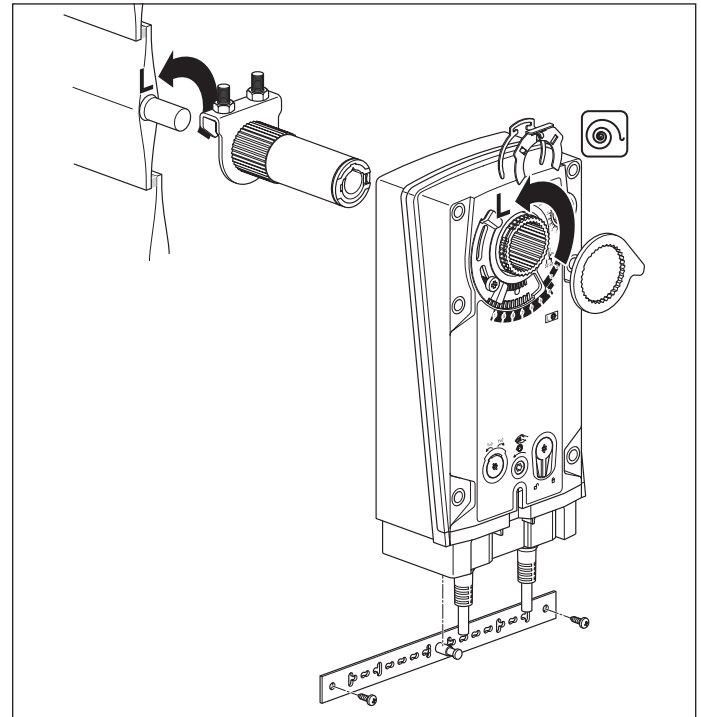
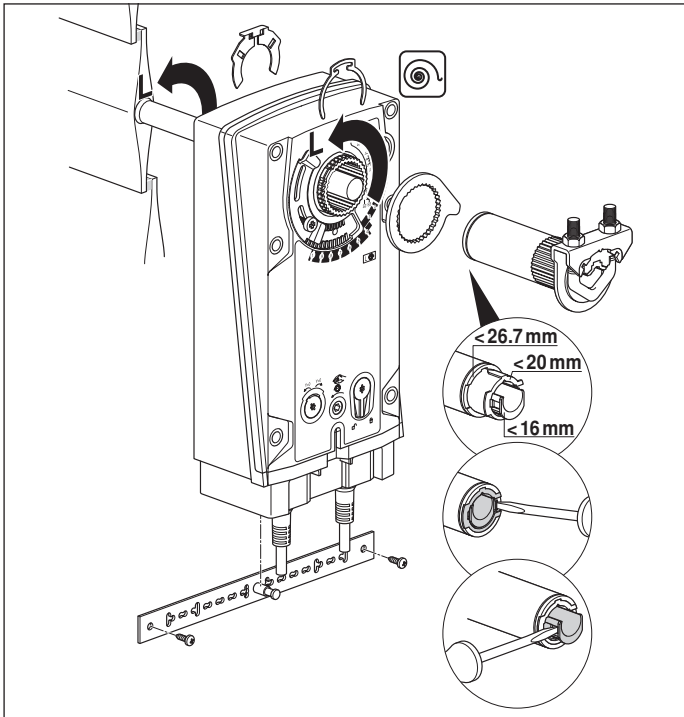
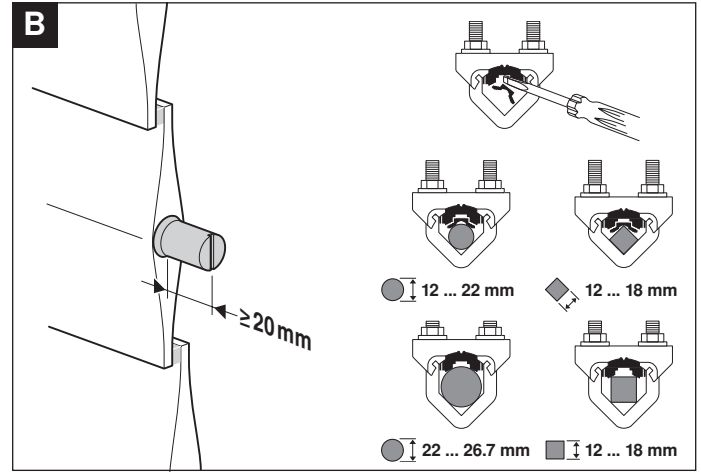
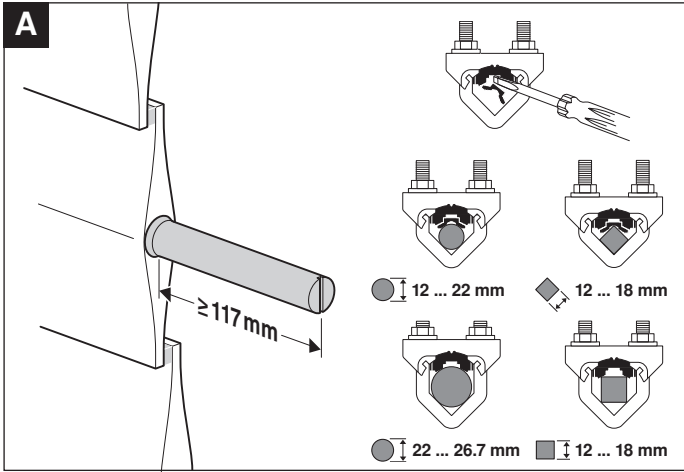

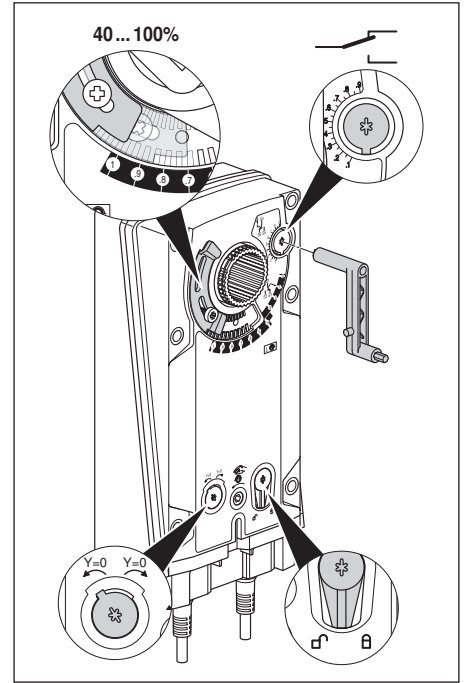
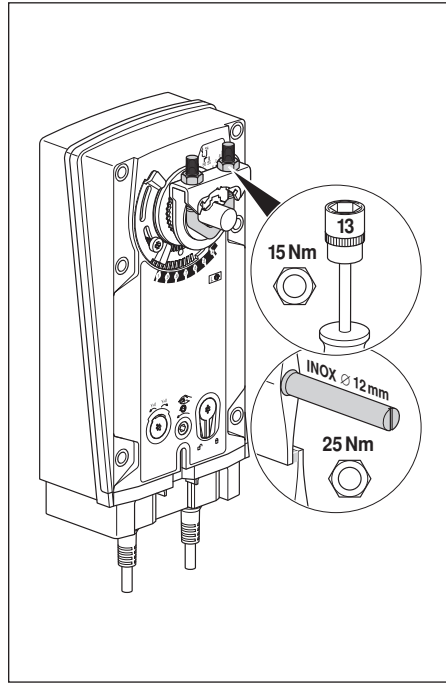
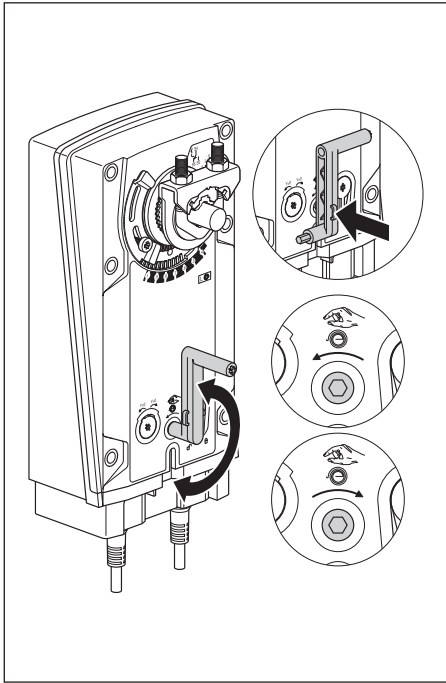

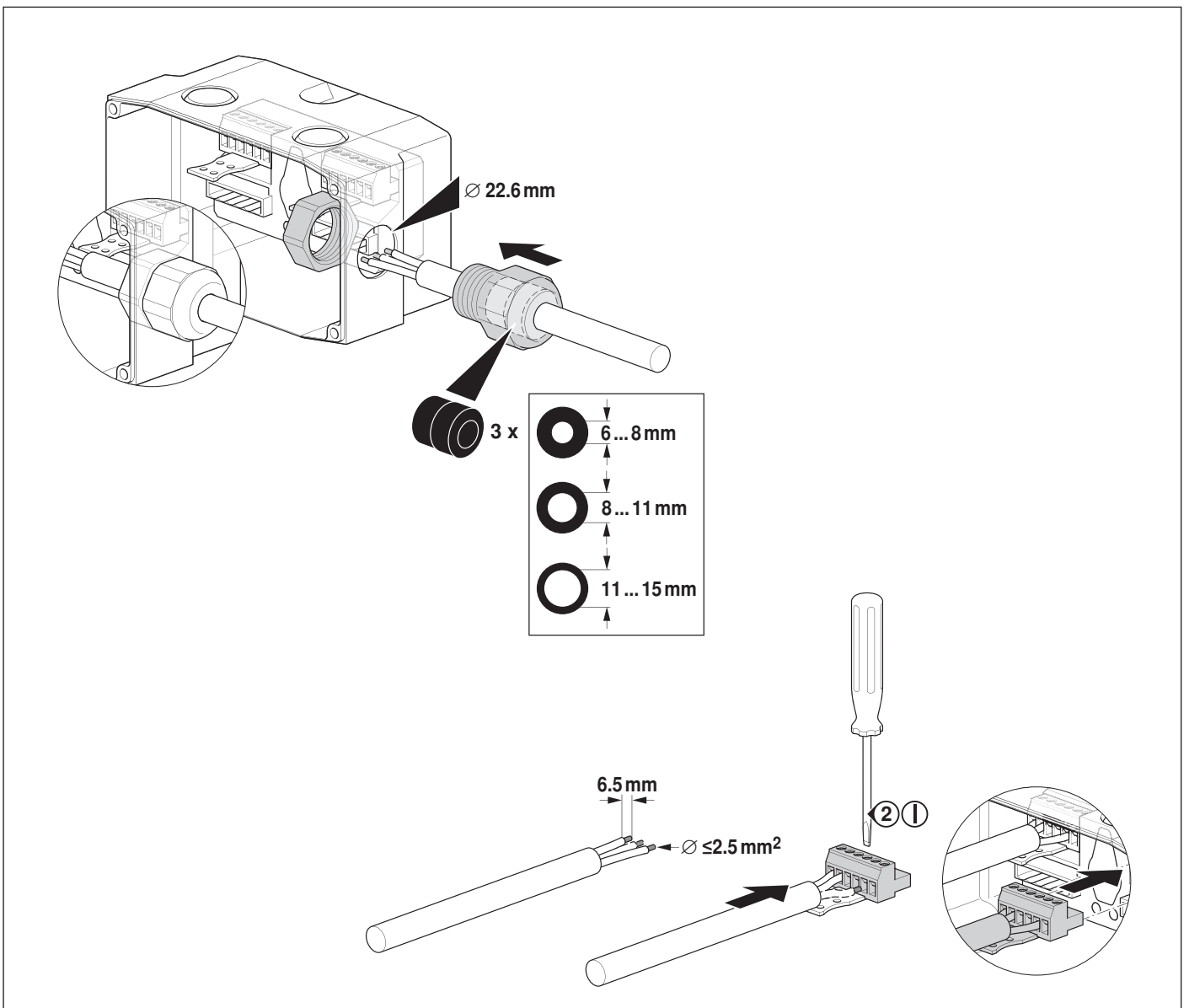
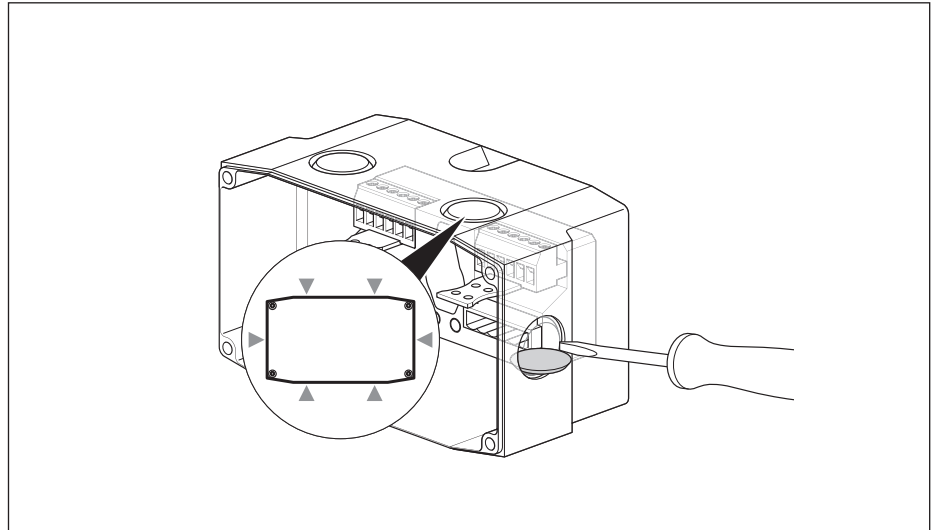
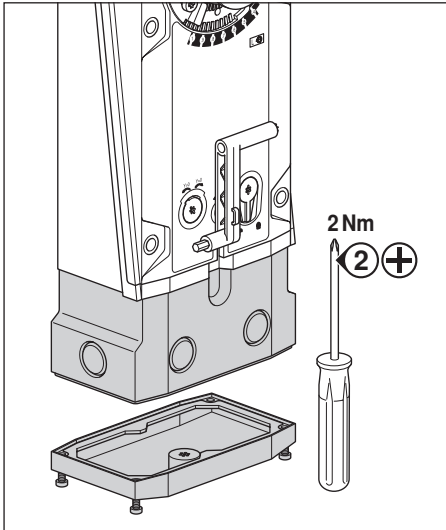

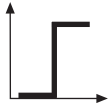

AC 24 V / DC 24 V

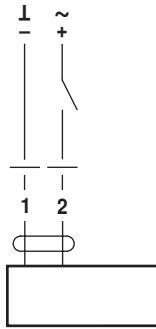

EF24A

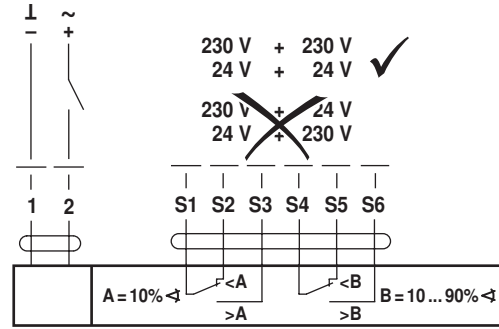

EF24A-S2

230 V + 230 V
24 V + 24 V ✓
~~230 V + 24 V~~
~~24 V + 230 V~~

AC 100 ... 240 V ⚠

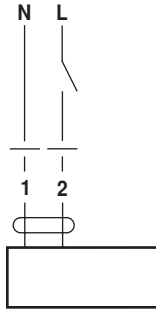

EF230A

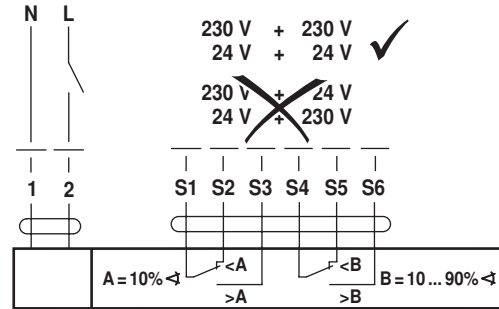

EF230A-S2

230 V + 230 V
24 V + 24 V ✓
~~230 V + 24 V~~
~~24 V + 230 V~~

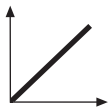

AC 24 V / DC 24 V

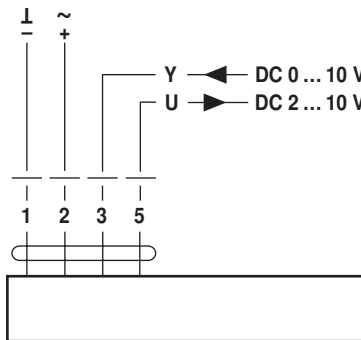

EF24A-SR
EF24A-MF

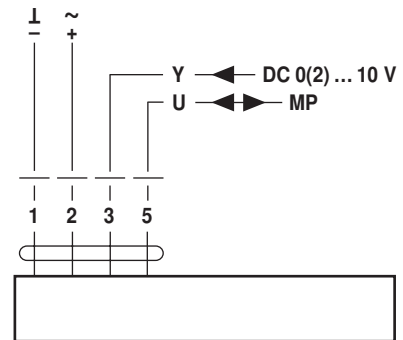

EF24A-MP

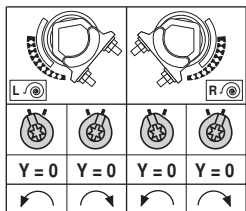

EF24A-SR
EF24A-SR-S2

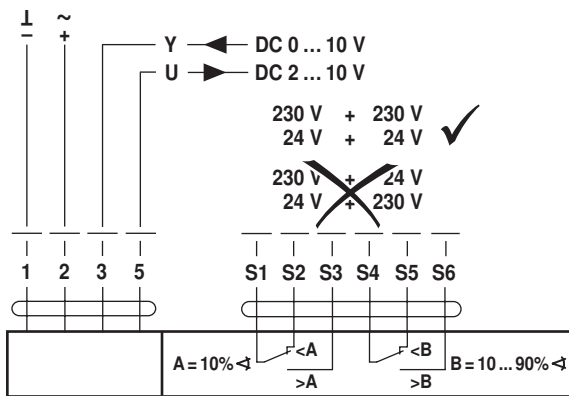

EF24A-SR-S2

230 V + 230 V
24 V + 24 V ✓
~~230 V + 24 V~~
~~24 V + 230 V~~