

Parameterisable damper actuator in the IP66 protective housing for adjusting air dampers in industrial plants and in technical building installations

- For air dampers up to approx. 8 m²
- Torque 40 Nm
- Nominal voltage AC/DC 24 V
- Control: Modulating DC 0 ... 10 V or variable
- Position feedback DC 2 ... 10 V or variable

Optimum weather protection for outdoor applications

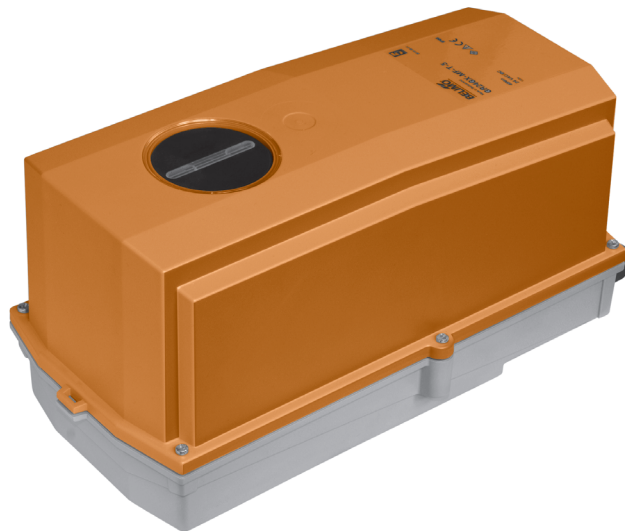

Technical data

Electrical data

Nominal voltage	AC 24 V, 50/60 Hz / DC 24 V
Nominal voltage range	AC 19.2 ... 28.8 V / DC 21.6 ... 28.8 V
Power consumption	4.5 W @ nominal torque
At rest	1.5 W
For wire sizing	7 VA (I _{max} 20 A @ 5 ms)
Connection	Terminals 4 mm ² (cable Ø 4 ... 10 mm)

Functional data	Factory settings	Variable	Settings
Torque (nominal torque)	Min. 40 Nm @ nominal voltage	25%, 50%, 75% reduced
Control Control signal Y	DC 0 ... 10 V, input impedance 100 kΩ	Open-close / 3-point (AC only), modulating (DC 0 ... 32 V)
Operating range	DC 2 ... 10 V	Start point DC 0.5 ... 30 V End point DC 2.5 ... 32 V
Position feedback (Measuring voltage U)	DC 2 ... 10 V, max. 0.5 mA	Start point DC 0.5 ... 8 V End point 2.5 ... 10 V
Position accuracy	±5%		
Direction of rotation	Reversible with switch 0 / 1		
Direction of motion at Y = 0 V	At switch position 0 ↶ or 1 ↷, respectively	Electronically reversible
Manual override	Gearing latch disengaged with pushbutton, can be locked		
Angle of rotation	Max. 95°↔, can be limited at both ends with adjustable mechanical end stops		
Running time	150 s / 90°↔	75 ... 290 s
Automatic adjustment of running time, operating range and measuring signal U to match the mechanical angle of rotation	Manual triggering of the adaption by pressing the «Adaption» button or with the PC-Tool	Automatic adaption whenever the supply voltage is switched on, or manual triggering
Override control	MAX (maximum position) = 100% MIN (minimum position) = 0% ZS (intermediate position, AC only) = 50%	MAX = (MIN + 30°↔) ... 100% MIN = 0% ... (MAX - 30°↔) ZS = MIN ... MAX
Sound power level	Max. 45 dB (A)	With a 75 s = 50 dB (A) running time of 290 s ≤ 40 dB (A)	
Position indication	Mechanical, pluggable		

Safety

Protection class	III Safety extra-low voltage UL Class 2 Supply
Degree of protection	IP66 NEMA 4, UL Enclosure Type 4
EMC	CE according to 2004/108/EC
Certification	Certified to IEC/EN 60730-1 and IEC/EN 60730-2-14 cULus according to UL 60730-1 and UL 60730-2-14 and CAN/CSA E60730-1:02
Mode of operation	Type 1
Rated impulse voltage	0.8 kV
Control pollution degree	4

Technical data	(continued)
Ambient temperature	-30 ... +50 °C
Non-operating temperature	-40 ... +80 °C
Ambient humidity	100% r.h.
Maintenance	Maintenance-free
Dimensions / Weight	
Dimensions	See «Dimensions» on page 6
Weight	Approx. 4.7 kg

Safety notes



- The actuator is not allowed to be used outside the specified field of application, especially in aircraft or in any other airborne means of transport.
- It may only be installed by suitably trained personnel. Any legal regulations or regulations issued by authorities must be observed during installation.
- The cover of the protective housing may be opened for adjustment and servicing. When it is closed afterwards, the housing must seal tight (see installation instructions).
- The device on the inside may only be opened up in the factory. It does not contain any parts that can be replaced or repaired by the user.
- When calculating the required torque, the specifications supplied by the damper manufacturers (cross-section, design, installation site), and the air flow conditions must be observed.
- The device contains electrical and electronic components and is not allowed to be disposed of as household refuse. All locally valid regulations and requirements must be observed.
- The actuator is not designed for applications where chemical influences (gases, fluids) are present or for utilisation in corrosive environments in general.
- The materials used may be subjected to external influences (temperature, pressure, constructional fixture), that cannot be simulated in laboratory test or field trials. In case of doubt, we definitely recommend that you carry out a test. This information does not imply any legal entitlement. Belimo will not be held liable and will provide no warranty.
- If cables which are not authorised for UL (NEMA) Type 4 applications are guided out of the unit, then flexible metallic cable conduits or threaded cable conduits of equal value are to be used.
- The actuator may not be used in plenum applications (e.g. suspended ceilings or raised floors).





Product features

Fields of application	<p>The actuator is particularly suitable for utilisation in outdoor applications and is protected against the following weather conditions:</p> <ul style="list-style-type: none"> – UV radiation – rain / snow – dirt / dust – humidity – Changing atmosphere / frequent and severe temperature fluctuations (recommendation: use the actuator with integrated factory-installed heating which can be ordered separately to prevent internal condensation *) <p>* in development</p>
------------------------------	--

Product features

(continued)

Mode of operation	The actuator is controlled with a standard modulating signal of DC 0 ... 10 V and travels to the position defined by the control signal. The measuring voltage U serves for the electrical display of the damper position 0 ... 100% and as slave control signal for other actuators.
Parameterisable actuators	The factory settings cover the most common applications. Input and output signals and other parameters can be altered with the MFT-P BELIMO service tool or with the ZTH-GEN adjustment and diagnostic tool.
Simple direct mounting	Simple direct mounting on the damper spindle with a universal spindle clamp, supplied with an anti-rotation strap to prevent the actuator from rotating.
Manual override	Manual override with pushbutton possible (the gear is disengaged for as long as the button is pressed or remains locked).
Adjustable angle of rotation	Adjustable angle of rotation with mechanical end stops. Standard setting 0 ... 90°<. The housing cover must be removed to set the angle of rotation.
High functional reliability	The actuator is overload-proof, requires no limit switches and automatically stops when the end stop is reached.
Home position	When the supply voltage is switched on for the first time, i.e. at commissioning or after pressing the «gear disengagement» switch, the actuator moves to the home position.

Pos. direction of rotation switch	Home position
 Y = 0  Y = 0 	ccw  Left stop cw  Right stop

The actuator then moves into the position defined by the control signal.

Accessories

	Description	Data sheet
Electrical accessories	Auxiliary switch S..A..	T2 - S..A..
	Feedback potentiometer P..A..	T2 - P..A..
	BELIMO service tool MFT-P	
	Adjustment and diagnostic device ZTH-GEN	
	Range controller SBG24	T2 - SBG24
	Positioner SGA24, SGE24 and SGF24	T2 - SG..24
	Digital position indicator ZAD24	T2 - ZAD24
	Heating with mechanical hygostat *	
	Heating with adjustable thermostat *	

* in development

Electrical installation

Wiring diagram

Notes

- Connection via safety isolating transformer! 
- Other actuators can be connected in parallel. Please note the performance data!

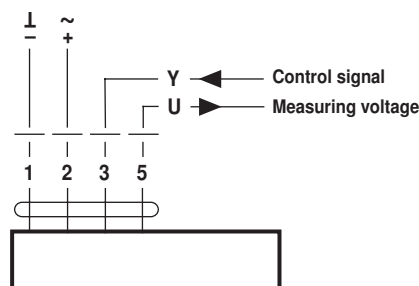

Functions with basic values

Override control with AC 24 V with relay contacts

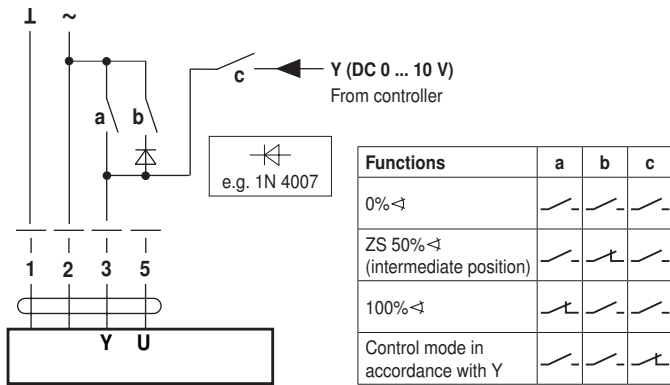

Override control with AC 24 V with rotary switch

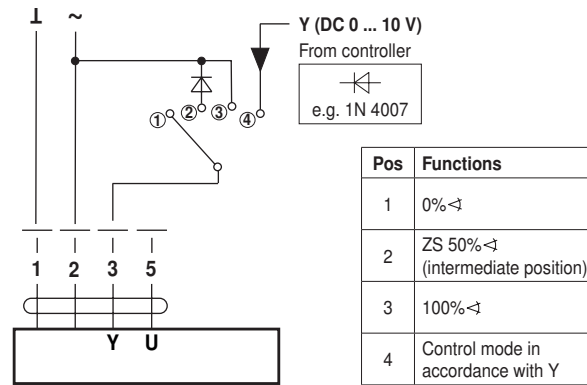

Remote control 0 ... 100%

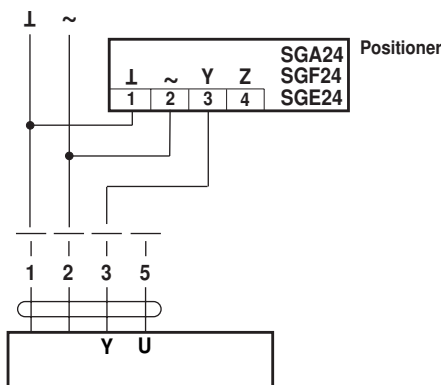

Minimum limit

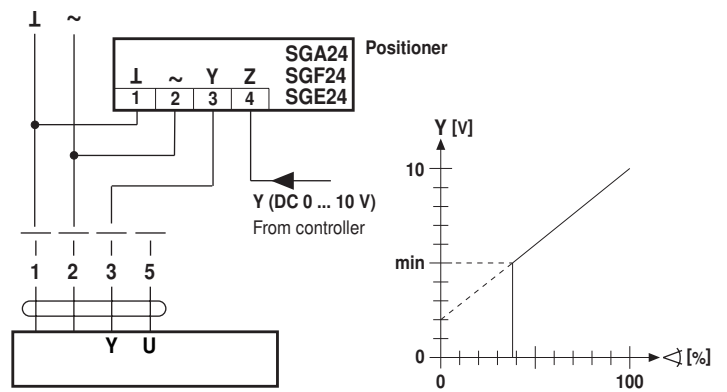

Master/Slave control (position-dependent)

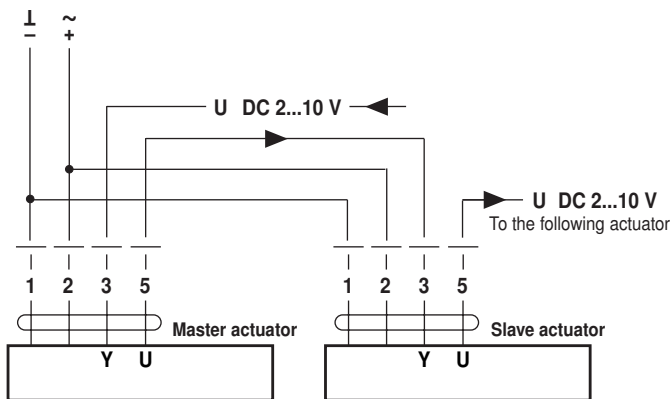

Control with 4 ... 20 mA via external resistance

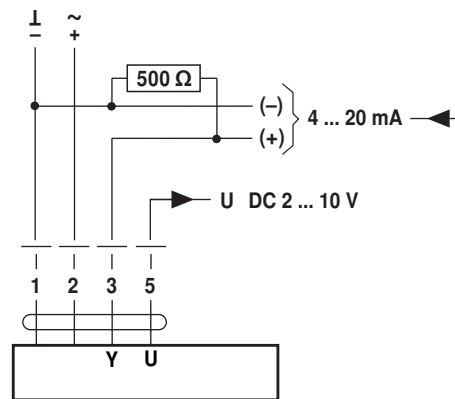

The 500 Ω-resistor converts the 4 ... 20 mA current signal to a voltage signal DC 2 ... 10 V

Position indication

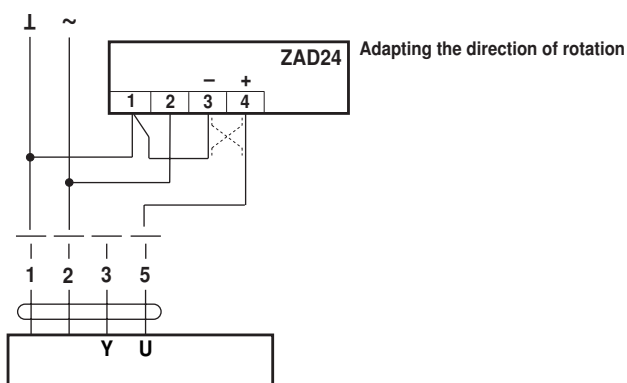

Functional check

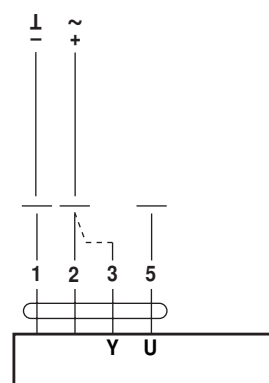

Procedure

- Apply 24 V to connection 1 and 2
- Disconnect connection 3:
 - For direction of rotation 0: Actuator turns in the direction of ↻
 - For direction of rotation 1: Actuator turns in the direction of ↻
- Short circuit connections 2 and 3:
 - Actuator runs in the opposite direction

Functions for actuators with specific parameters

Override control and limiting with AC 24 V with relay contacts

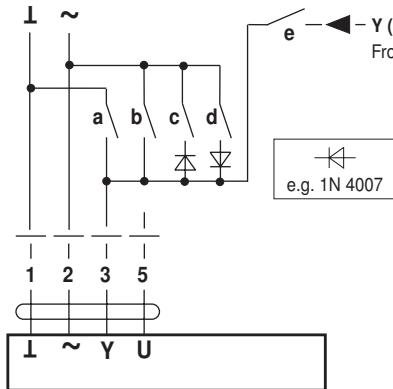

Functions	a	b	c	d	e
CLOSE 1)	—	—	—	—	—
MIN	—	—	—	—	—
ZS (intermediate position)	—	—	—	—	—
MAX	—	—	—	—	—
OPEN	—	—	—	—	—
Control mode in accordance with Y	—	—	—	—	—

Override control and limiting with AC 24 V with rotary switch

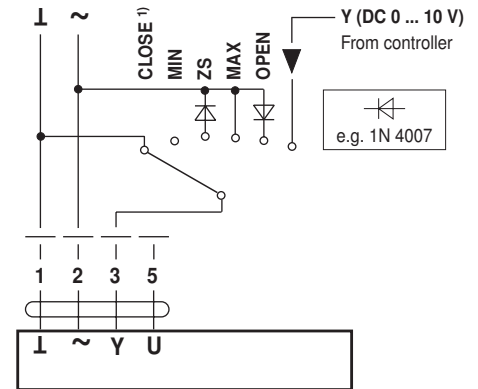

1) **Caution!** This function is only guaranteed if the start point of the operating range is defined as min. 0.6 V.

3-point control

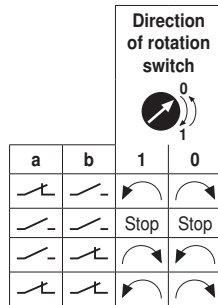
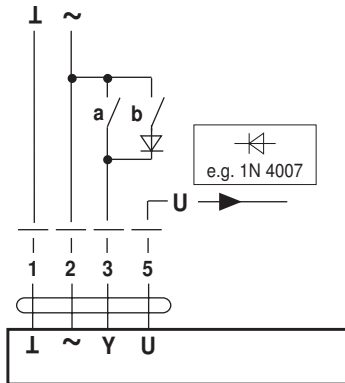

Open-close control

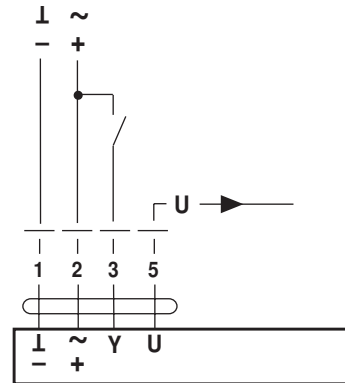

Operating controls and indicators

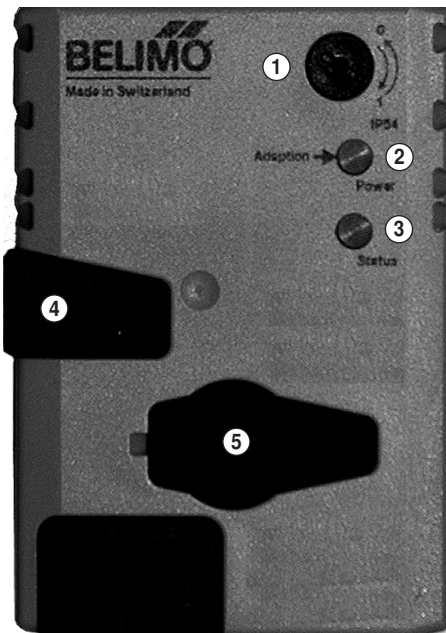

- ① **Direction of rotation switch**
Switching over: Direction of rotation changes
- ② **Pushbutton and green LED display**
Off: No voltage supply or malfunction
On: Operation
Press button: Switches on angle of rotation adaption followed by standard operation
- ③ **Pushbutton and yellow LED display**
Off: Standard operation
On: Adaption or synchronising process active
Press button: No function
- ④ **Gear disengagement switch**
Press button: Gear disengaged, motor stops, manual operation possible
Release button: Gear engaged, synchronisation starts, followed by standard operation
- ⑤ **Service plug**
For connecting parameterising and service tools

Check voltage supply connection

- a) ② Off and ③ On } Check the supply connections.
- b) ② Blinking and ③ Blinking } Possibly L and ~ are swapped over.

Dimensions [mm]

Dimensional drawings

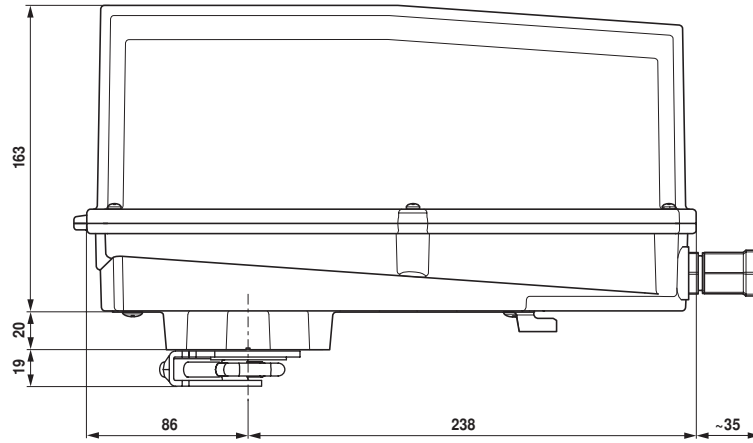

Damper spindle	Length			
	16 ... 75	14 ... 26.7	≥12	≤25.5

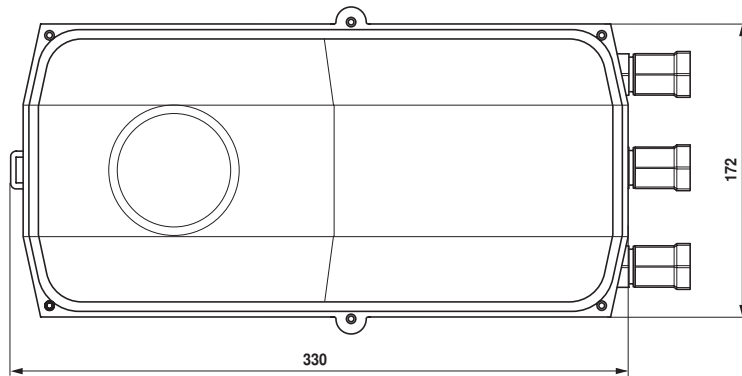
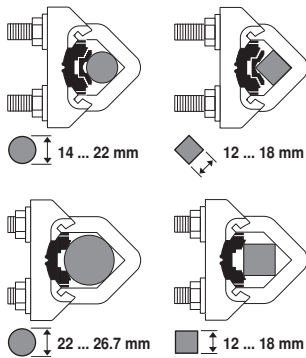

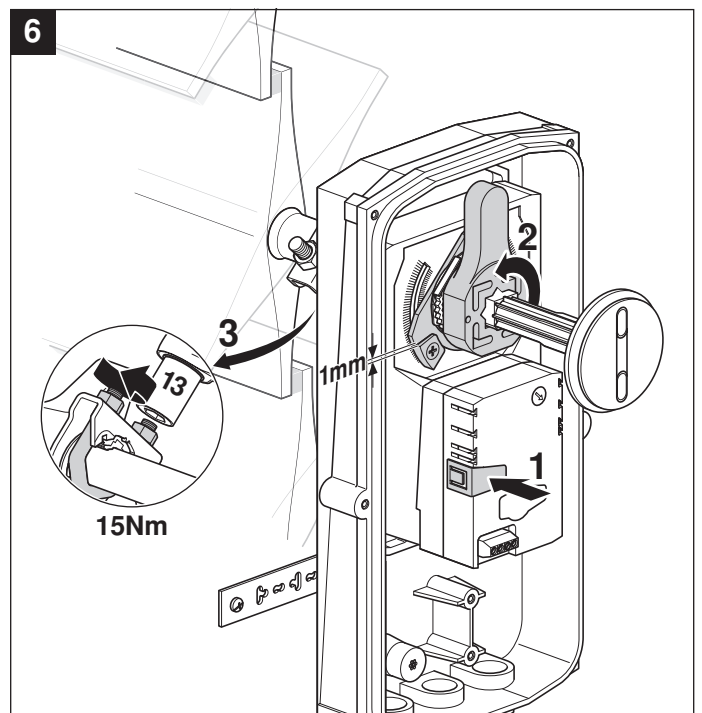
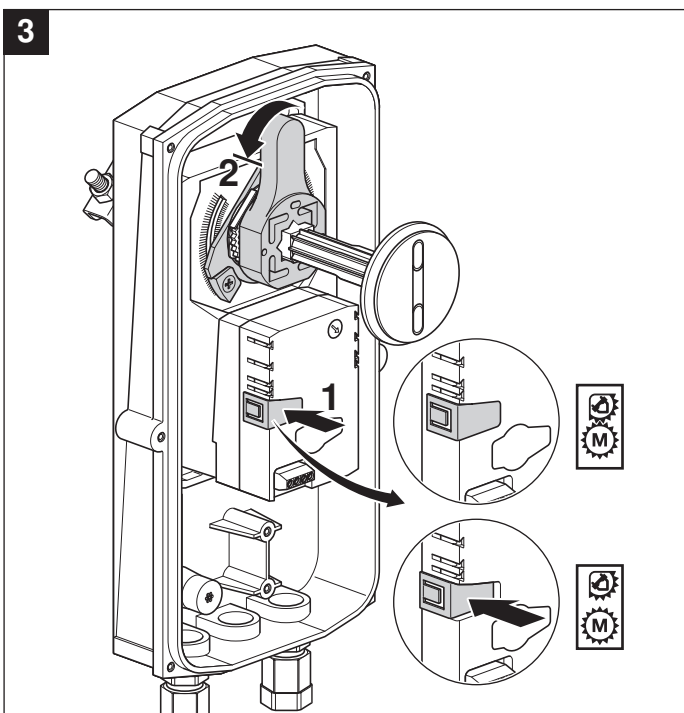
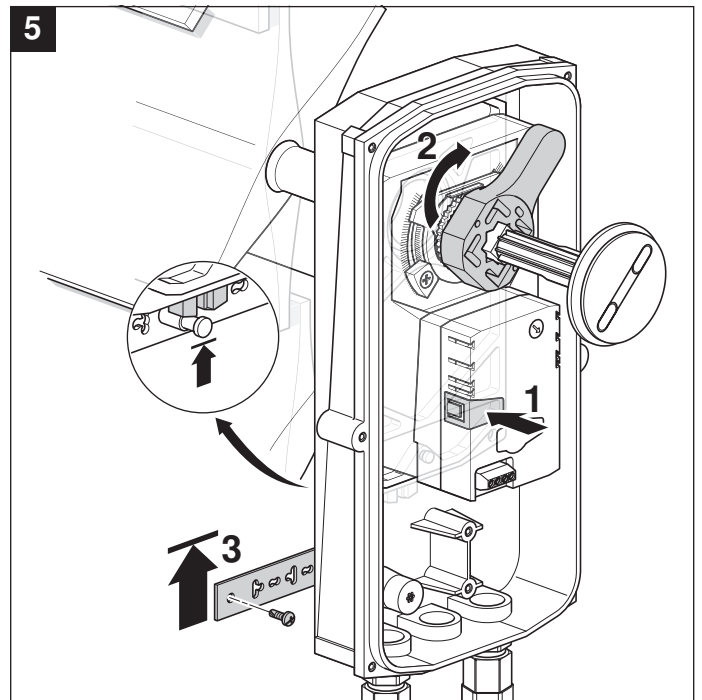
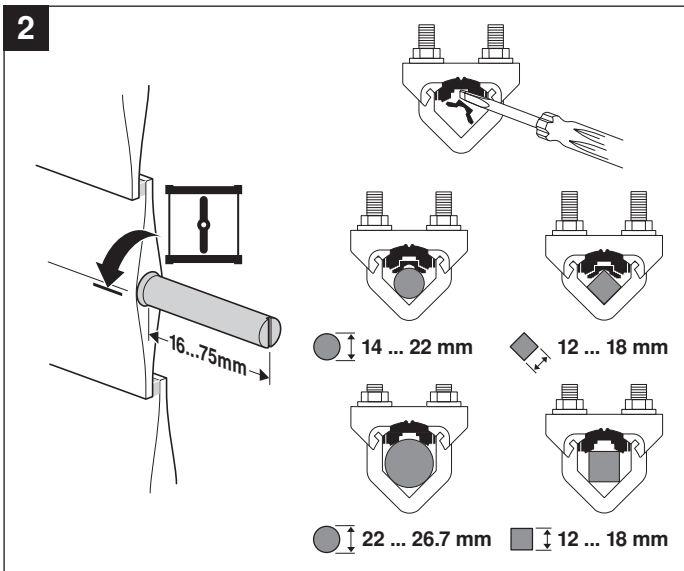
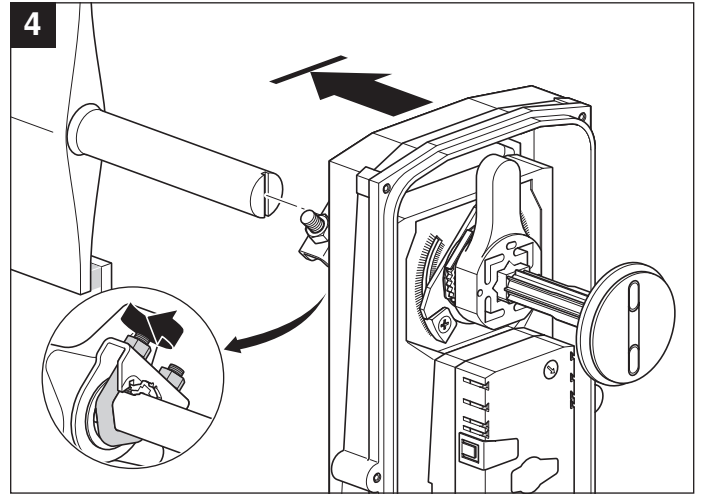
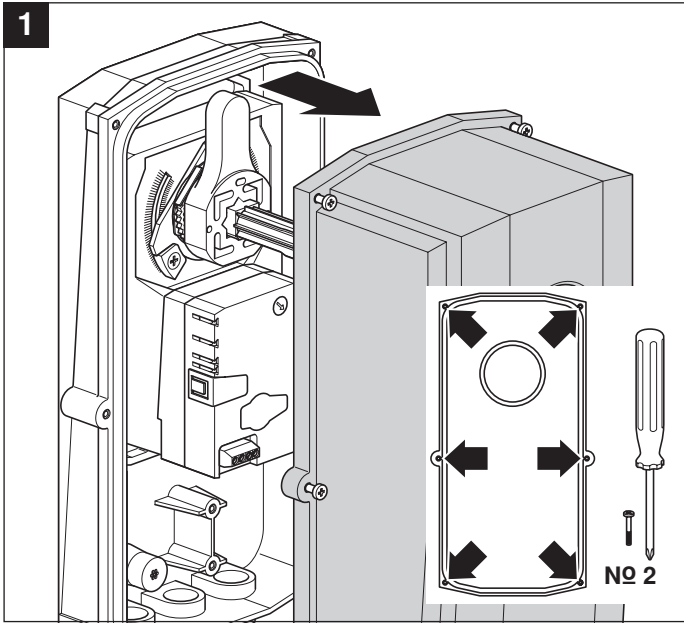

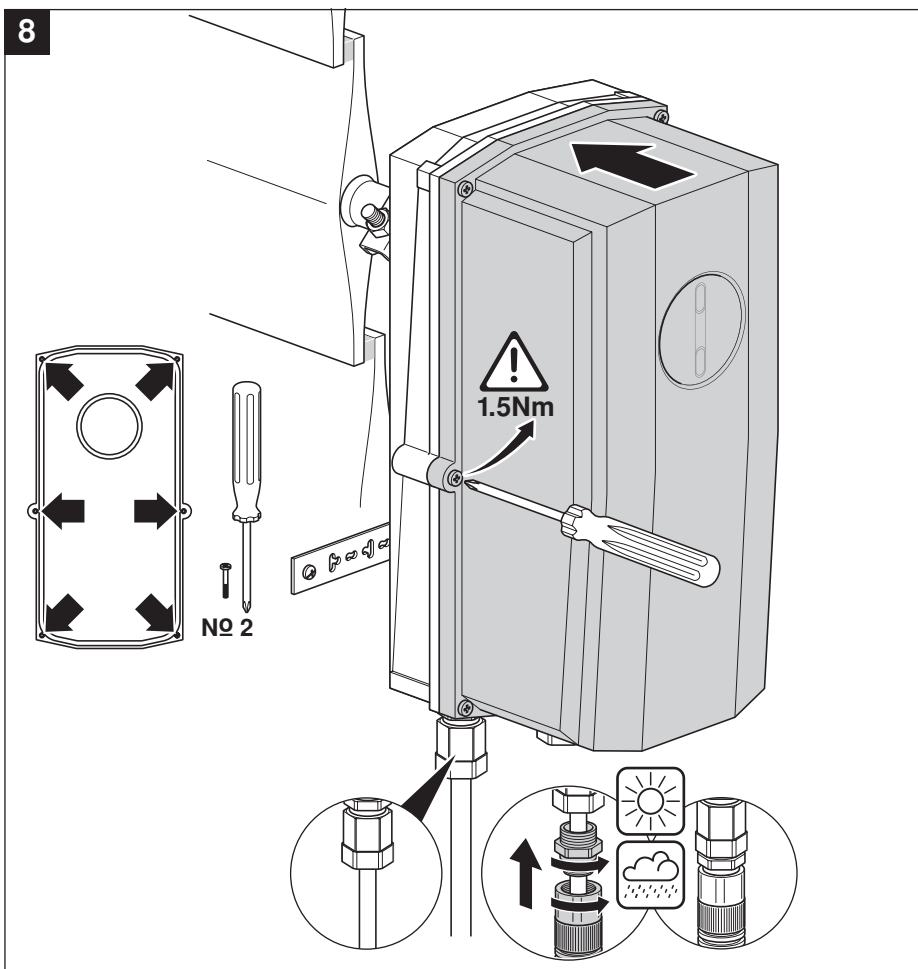
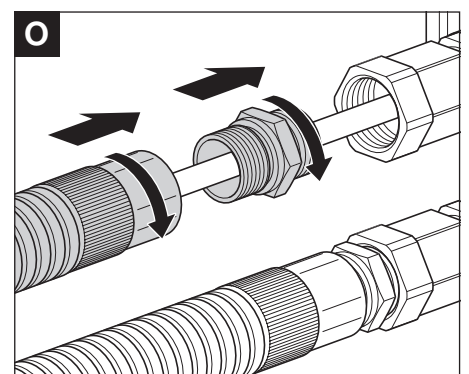
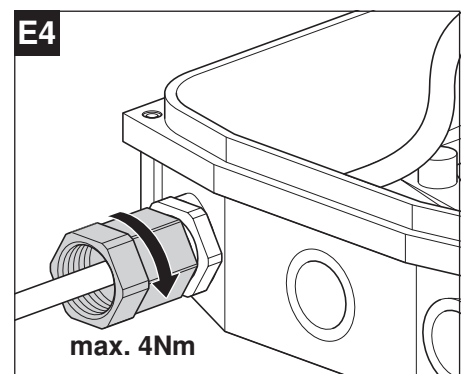
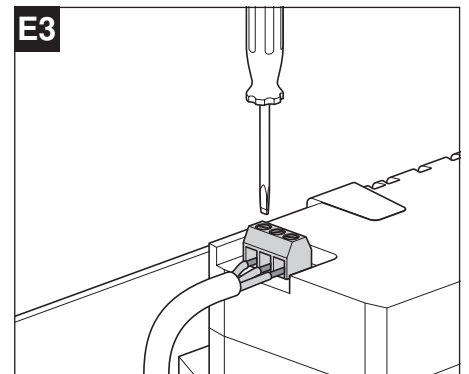
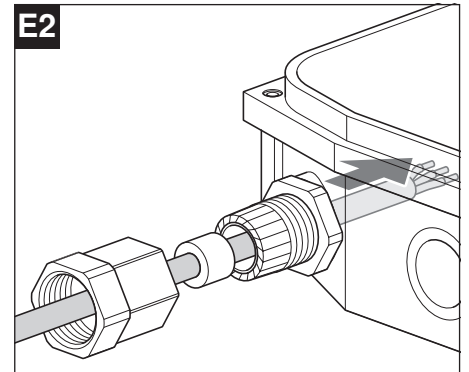
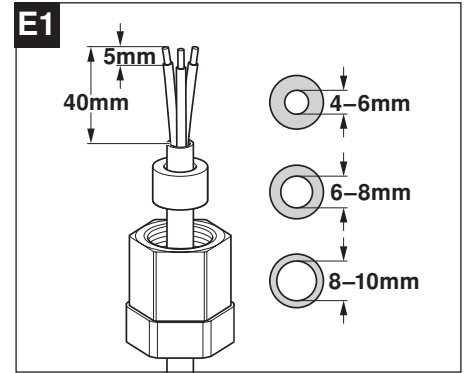
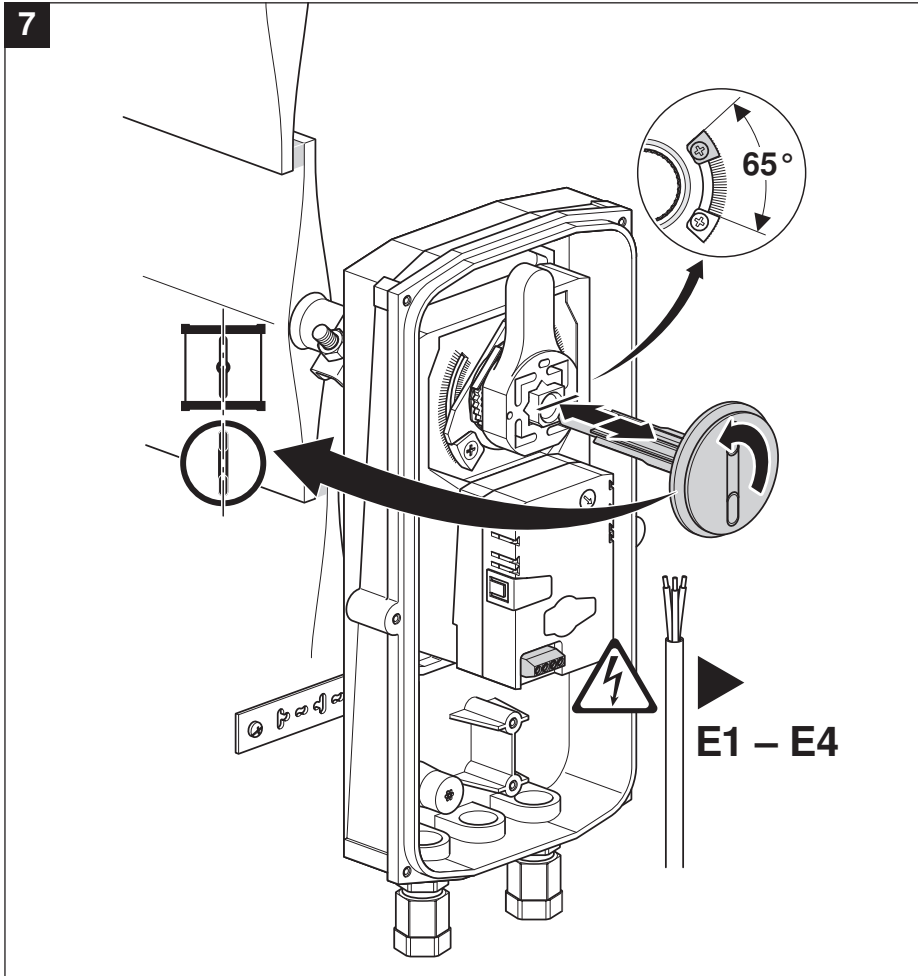

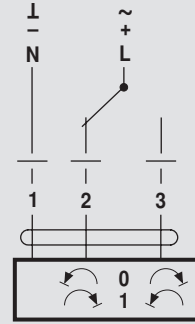
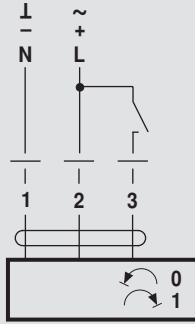

AC 24 V / DC 24 V

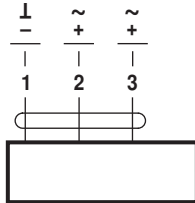

GM24G-T

AC 100 ... 240 V

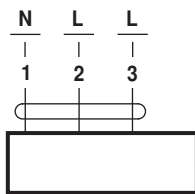

GM230G-T

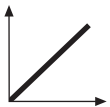

AC 24 V / DC 24 V

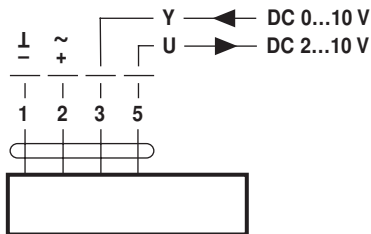

GM24G-SR-T
GM24G-MF-T

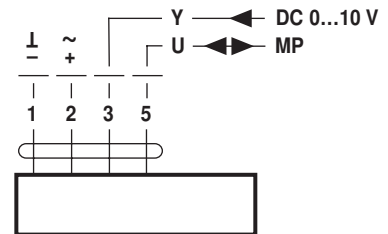

GM24G-MP-T