

Linear actuator for

2-way and 3-way globe valves

- Actuating force 1000 N
- Nominal voltage AC/DC 24 V
- Control 3-point
- NV24-3 with cable connection  
NV24-3-T with terminal connection
- Brackets and adapter sets for third-party valves as accessories (UNV-..)

**Technical data**

<b>Electrical data</b>	Nominal voltage	AC 24V, 50/60 Hz / DC 24V
	Nominal voltage range	AC 19.2 ... 28.8V / DC 21.6 ... 28.8V
	Power consumption	Operation 1.5 W @ nominal force
		For wire sizing 3 VA
	Connection	NV24-3 Cable 1 m, 3 x 0.75 mm <sup>2</sup> NV24-3-T Terminal connection
	Parallel operation	Yes (note performance data for supply!)
<b>Functional data</b>	Actuating force	Closing force 1000 N
		Inhibiting force 800 N
	Manual override	With hexagon socket screw key, temporary
	Nominal stroke	20 mm
	Actuating time	7.5 s/mm or 3.75 s/mm, selectable
	Sound power level	≤35 dB (A)
	Position indication	mechanical 5 ... 20 mm stroke
<b>Safety</b>	Protection class	III Safety extra-low voltage
	Degree of protection	IP54
	EMC	CE according to 2004/108/EC
	Mode of operation	Type 1 (EN 60730-1)
	Rated impulse voltage	0.33 kV (EN 60730-1)
	Control pollution degree	3 (EN 60730-1)
	Ambient temperature	0 ... +50 °C
	Non-operating temperature	-40 ... +80 °C
	Ambient humidity	95% r.h., non-condensating (EN 60730-1)
	Maintenance	Maintenance-free
<b>Dimensions / Weight</b>	Dimensions	See «Dimensions» on page 4
	Weight	approx. 1.5 kg with bracket UNV-002 (without valve)

**Safety notes**

- The actuator has been designed for use in stationary heating, ventilation and air conditioning systems and is not allowed to be used outside the specified field of application, especially in aircraft or in any other airborne means of transport.
- It may only be installed by suitably trained personnel. Any legal regulations or regulations issued by authorities must be observed during assembly.
- The device does not contain any parts that can be replaced or repaired by the user.
- The device contains electrical and electronic components and is not allowed to be disposed of as household refuse. All locally valid regulations and requirements must be observed.

**Product features**

<b>Mode of operation</b>	The actuator is activated with a 3-point signal.
<b>Installation on Belimo valves</b>	<p>If a combination of actuator and BELIMO globe valve is ordered, then one <b>UNV-002</b> bracket is included in the scope of delivery.</p> <p>If an actuator is ordered without Belimo globe valve, then the <b>UNV-002</b> bracket (see «Accessories») must also be ordered.</p>
<b>Installation on third-party valves</b>	<p>Prior to installation on a third-party valve, a suitable bracket <b>UNV-..</b> (see «Accessories») must first be screwed to the actuator. The adapter set integrated therein is comprised of a valve neck adapter and a valve stem adapter. The valve neck adapter, together with a clamping strap on the bracket, makes possible simple installation of the actuator on the valve neck. The valve stem adapter is mounted on the valve stem. The actuator spindle can be coupled to the valve stem with the valve stem coupling.</p> <p>The actuator can be rotated by 360° ↺ on the valve neck.</p> <p>Retrofit actuators <b>NV.. -R</b> are also available which are equipped with a Retrofit bracket and which can be used with corresponding <b>ZNV-..</b> (adapter set) for valves from a wide array of manufacturers.</p>
<b>Manual override</b>	The stroke can be adjusted in a voltage-free state by using a hexagon socket screw key (5 mm), which is plugged into the actuator at the top. If the hexagonal key is turned in a clockwise direction, then the actuator spindle will extend from the actuator housing (pushing) and maintain the position until a nominal voltage is applied (the controller has first priority).
<b>Functional reliability</b>	The actuator is protected against short circuits, polarity reversal and overloading.
<b>Position indication</b>	The stroke is indicated mechanically on the bracket. The stroke range adjusts itself automatically.
<b>Combination valve/actuator</b>	Refer to the Belimo valve documentation for suitable valves, their permitted media temperatures and closing pressures.

**Accessories**

	Description
<b>Mechanical accessories</b>	Brackets and adapter sets UNV-.. <span style="float: right;">see <a href="http://www.belimo.eu/retrofit">www.belimo.eu/retrofit</a></span>

**Electrical installation**

**Wiring diagram**

**Notes**

- Connect via safety isolation transformer.
- Parallel connection of other actuators possible. Note performance data for supply.

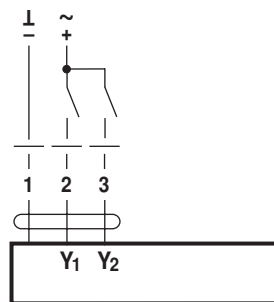

**Cable colours:**  
 1 = black  
 2 = red  
 3 = white

**Functions**

**Alignment of the operating elements**

The terminals for the cable connection and the operating element S1 are located under the cover of the actuator.

By setting slide switch S1 it is possible to configure the actuator very simply on site to suit actual requirements.

S1.1 Actuating time

S1.2 Valve closing point

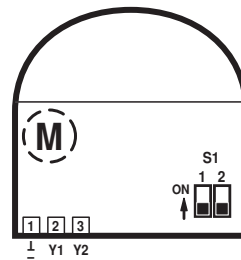
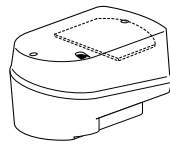

<b>S1.1</b>	<b>Symbol</b>
	7.5 s/mm →
	3.75 s/mm →
<b>S1.2</b>	<b>Symbol</b>
	▲ H4/5..B H6/7..N H6/7..R H7..X..S2 H7..Y..S2
	▼ H6..S H6..SP H6..X..S(P)2

**Functional description**

Function	Description	Switch		
Actuating time	The running time for full stroke varies as a function of the nominal stroke. (The running time for a 20 mm stroke and the standard actuating time is 150 s).	S1.1		
standard <sup>1)</sup>	Actuating time 7.5 s/mm	OFF	7.5 s/mm →	
fast	Actuating time 3.75 s/mm	ON	3.75 s/mm →	
Valve closing point	Closing point with linear spindle retracted or extended.	S1.2	<b>Symbol</b>	<b>Consequence</b>
up <sup>2)</sup>	The actuator spindle is retracted into the actuator and the valve stem is extended from the fitting.	OFF	▲	
down <sup>3)</sup>	The linear spindle is extended from the actuator and the valve stem is retracted into the fitting.	ON	▼	

<sup>1)</sup> Factory settings

<sup>2)</sup> Standard setting for valves H4..B, H5..B, H6..N, H6..R, H7..N, H7..R, H7..X..S2 and H7..Y..S2

<sup>3)</sup> Standard setting for valves H6..S, H6..SP and H6..X..S(P)2

**3-point control**

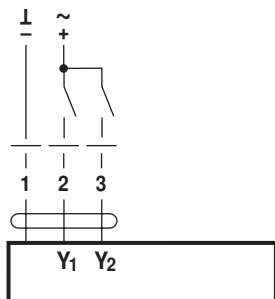

Actuating time	Closing point Valve	Symbols				Relay contact (Y1)	Relay contact (Y2)	Linear spindle moves	
		Actuating time standard	Actuating time fast	Closing point up	Closing point down				
7.5 s/mm →	▲	OFF		OFF		0	0	stops	stops
	▼	OFF			ON	1	0	ON	OFF
	▲		ON	OFF		0	1	ON	OFF
	▼		ON		ON	1	0	ON	OFF

**Note**

The actuator spindle direction can also be reversed by inverting the Y1 and Y2 wires.

## Dimensions [mm]

Dimensional drawings

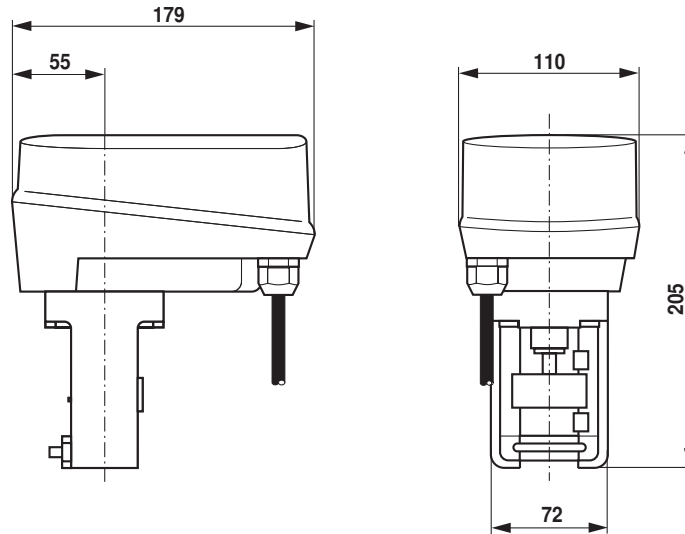
**Further documentation**

- Overview of brackets and adapter sets on [www.belimo.eu/retrofit](http://www.belimo.eu/retrofit)
- Complete overview «The complete product range of water solutions»
- Data sheets for globe valves
- Installation instructions for actuators and/or globe valves, respectively
- Notes for project planning (hydraulic characteristic curves and circuits, installation regulations, commissioning, maintenance, etc.)
- Specification texts

**BELIMO**



**NV(D)230-3  
NV24-3**



**NV230-3-R  
NV24-3-R**

70340-00001.A

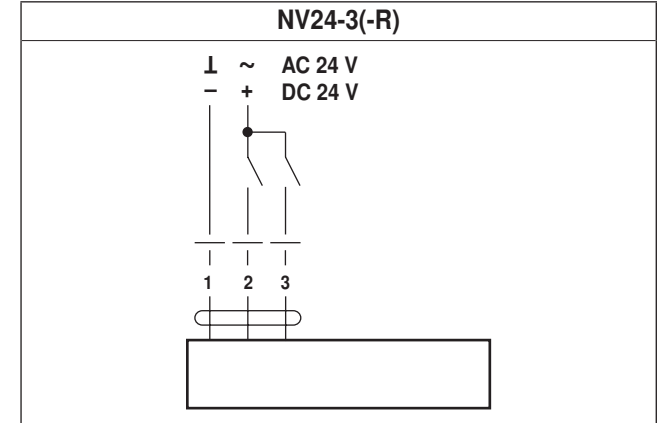
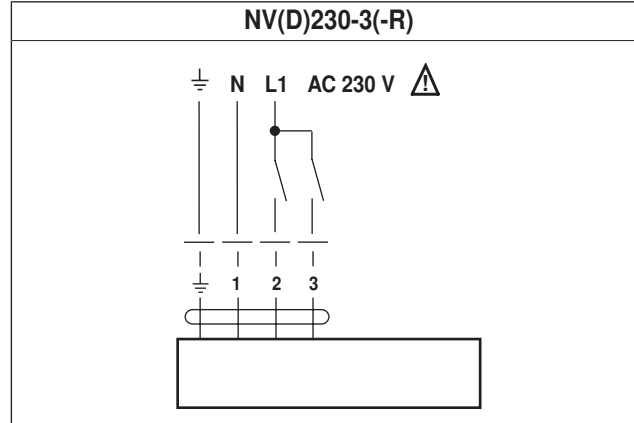

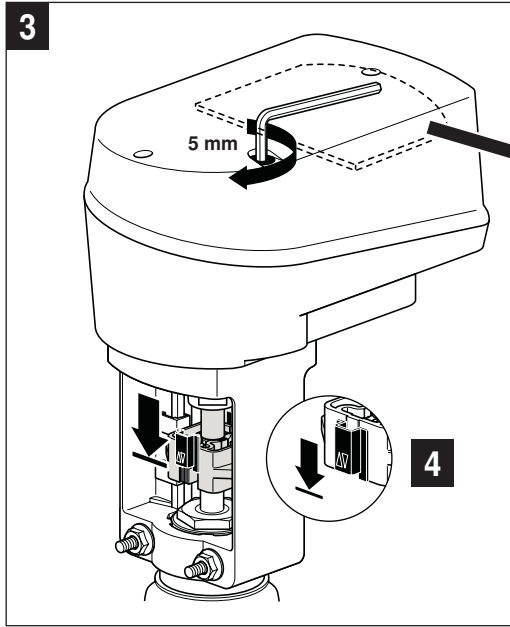
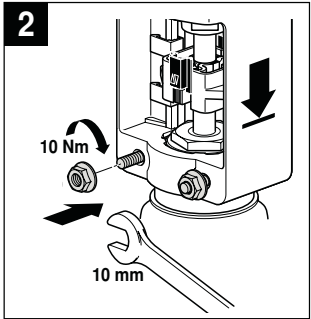
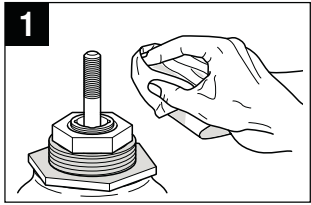

**5**

S1.1	Symbol
	7.5 s/mm
	3.75 s/mm
S1.2	Symbol
	H4/5..B H6/7..N H6/7..R H7..X..S2 H7..Y..S2
	H6..S H6..SP H6..X..S(P)2

! Warning symbol

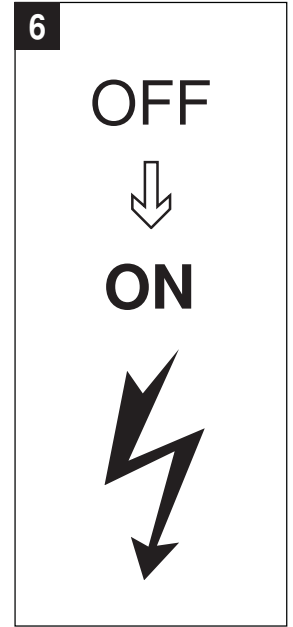

0...50°C

< 30 mm

H6..S / H6..SP max. 150°C  
 H4..B / H5..B max. 120°C  
 H6..N / H7..N max. 120°C  
 H6..R / H7..R max. 120°C  
 H6..X..S2 max. 150°C  
 H7..X..S2 max. 200°C\*  
 H7..Y..S2 max. 200°C\*

