

Rotary actuators for butterfly valves

- Torque 35 Nm
- Nominal voltage AC 24 V
- Control: Open-close or 3-point
- Auxiliary switch

Technical data

Electrical data	Nominal voltage	AC 24 V, 50/60 Hz
	Power supply range	AC 19.2 ... 28.8 V
	Power consumption	10 W at nominal torque
	Current consumption	0,6 A
	Auxiliary switch	2 x SPDT, 3 A, AC 250 V II □ Switching points: 90° ↺ adjustable
	Connection	Terminals, 2 x 1.5 mm ² or 1 x 2.5 mm ²
	Parallel connection	No
Functional data	Torque (nominal torque)	Min. 35 Nm at nominal voltage
	Manual override	Temporary with flat spanner
	Angle of rotation	90° ↺ (internal electrical stops)
	Running time	15 s
	Position indication	Mechanical
Safety	Protection class	III Extra low voltage
	Degree of protection	IP67
	EMC	CE according to 89/336/EEC
	Mode of operation	Typ 1 (to EN 60730-1)
	Nominal current voltage	0,8 kV (to EN 60730-1)
	Control pollution degree	4 (to EN 60730-1)
	Ambient temperature range	-20 ... +65°C (Duty cycle 13/4 s)
	Media temperature	-20 ... +100°C (in the butterfly valve)
	Non-operating temperature	-30 ... +80°C
	Ambient humidity range	95% r.H., non-condensating (to EN 60730-1)
Maintenance	Maintenance-free	
Mechanical data	Connection flange / stem	ISO 5211 / F05
	Housing material	Cast aluminium
Dimensions / Weight	Dimensions	See «Dimensions» on page 2
	Weight	Approx. 2 kg (without butterfly valve)

Safety notes

- The actuator has been designed for use in stationary heating, ventilation and air conditioning systems and is not allowed to be used outside the specified field of application, especially in aircraft or in any other airborne means of transport.
- It may only be installed by suitably trained personnel.
All applicable legal or institutional installation regulations must be complied with.
- The device may only be opened at the manufacturer's site. It does not contain any parts that can be replaced or repaired by the user.
- Make sure that the maximum length of insulation removed does not exceed 50 mm.
- The device contains electrical and electronic components and is not allowed to be disposed of as household refuse. All locally valid regulations and requirements must be observed.

Product features

- Simple direct mounting** Simple direct mounting on the butterfly valve. The mounting position in relation to the butterfly valve can be selected in 90° steps.
- Manual override** Manual override with flat spanner (turn clockwise opens the butterfly valve).
- Internal heating** An internal heater prevents condensation buildup.
- High functional reliability** The internal limit switches interrupt the voltage supply to the motor. In addition, a motor thermostat provides overload protection because at 135°C it interrupts the voltage supply.
- Combination butterfly valve actuators** Refer to the butterfly valve documentation for suitable butterfly valves, their permitted media temperatures and closing pressures.

Electrical installation

Wiring diagram

Note
Connect via safety isolation transformer.

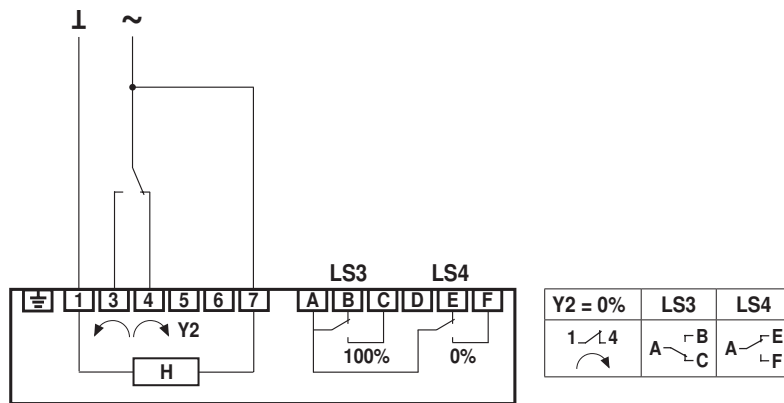

H Internal heating LS3 Auxiliary switch 100% (butterfly valve open)
 LS4 Auxiliary switch 0% (butterfly valve closed)

Dimensions [mm]

Dimensional diagrams

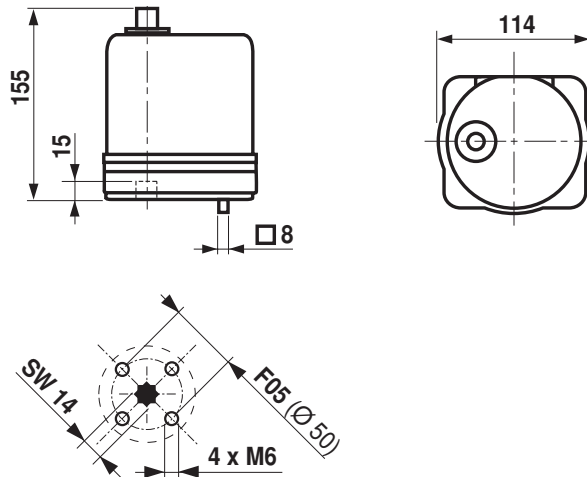

Settings

Setting cam

The setting cams for limit and auxiliary switches can be accessed by removing the housing cover.

Optionally, auxiliary switches LS4/LS3 can be connected for signalling.

Limit switches LS2/LS1 interrupt the voltage to the motor and are controlled by setting cams TC..

The setting cams turn with the spindle. The butterfly valve closes when the stem is turning clockwise (cw) and opens when the stem is turning counterclockwise (ccw).

Important !

Settings are only allowed to be made by authorised specialist personnel.

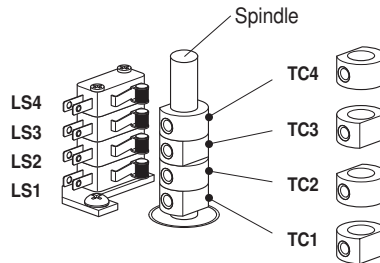

Settings of setting cams TC..

- TC4 for auxiliary switch position closed (factory setting 3°↺).
- TC3 for auxiliary switch position open (factory setting 87°↺).
- TC2 for limit switch closed (factory setting 0°↺).
- TC1 for limit switch open (factory setting 90°↺).

Adjusting setting cams

- 1 Use a 2.5 mm Allen key to unscrew the corresponding setting cams TC..
- 2 Turn the setting cam using the Allen key
- 3 Set as shown in the illustration below
- 4 Use the Allen key to tighten the setting cams

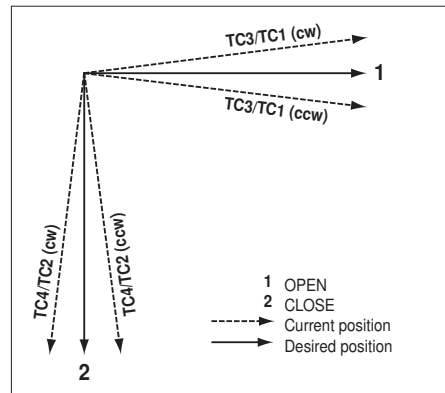

Further documentations

- Complete overview of actuators for water solutions
- Data sheets for butterfly valves
- Installation instructions for actuators and/or butterfly valves
- Notes for project planning (hydraulic characteristic curves and circuits, installation regulations, commissioning, maintenance etc.)

70545-00001.B

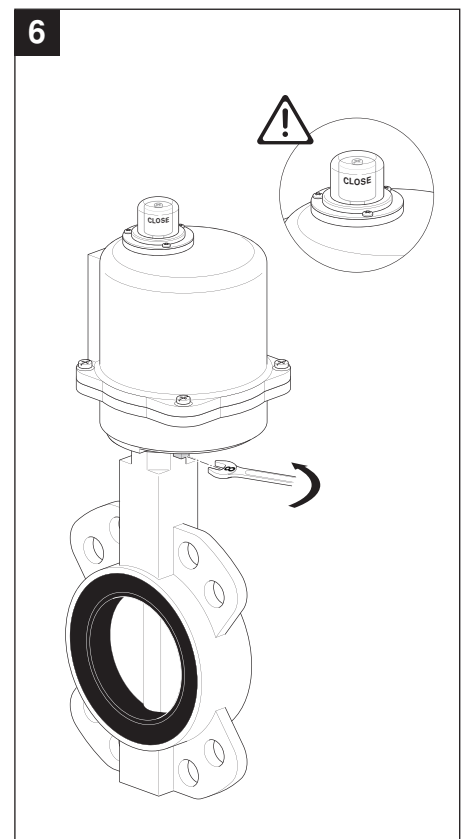
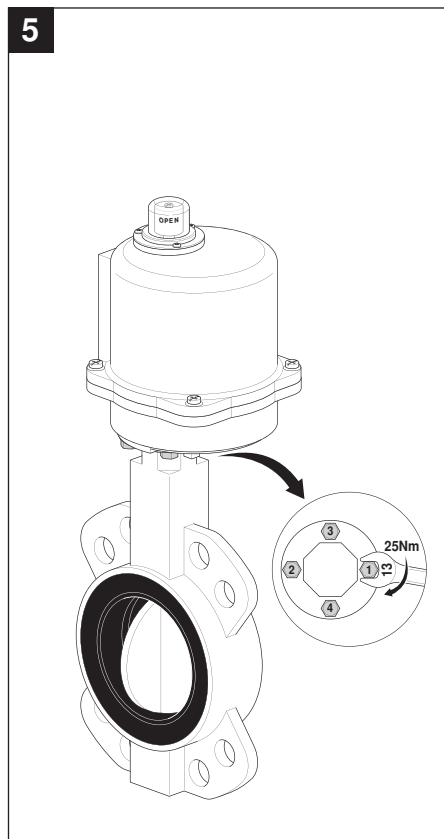
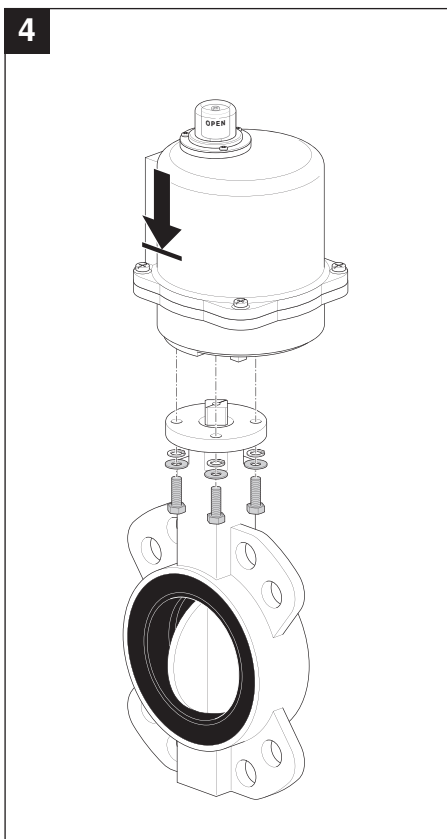
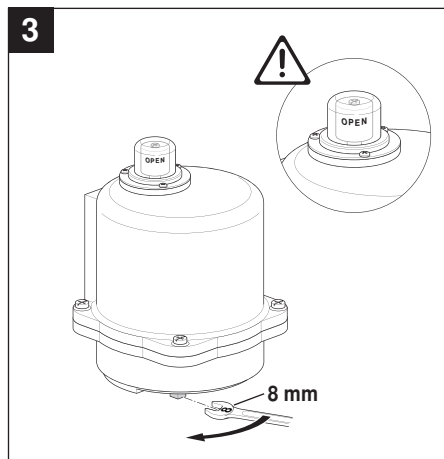
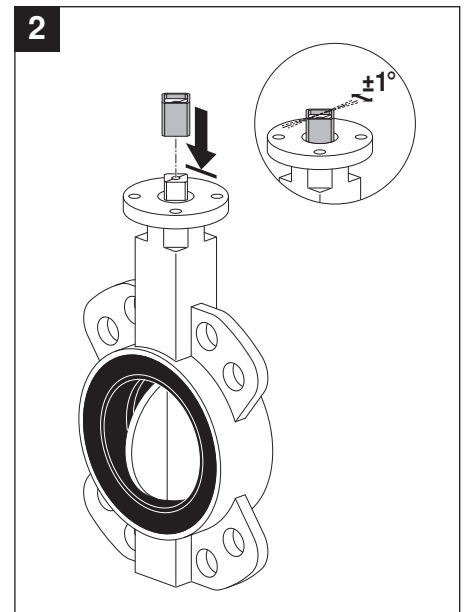
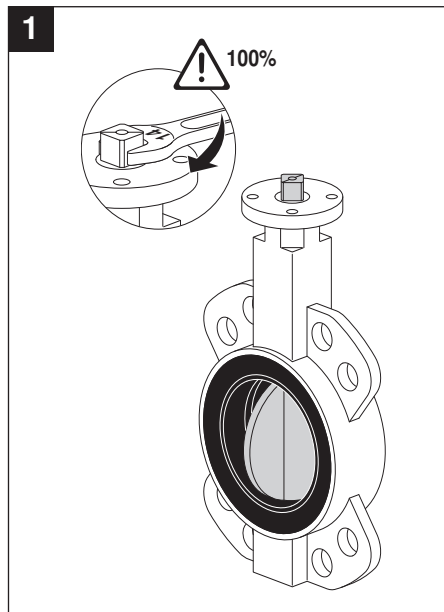
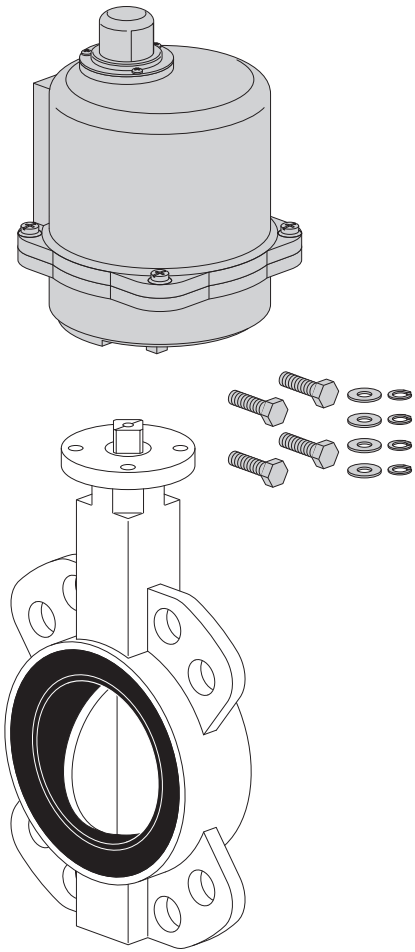

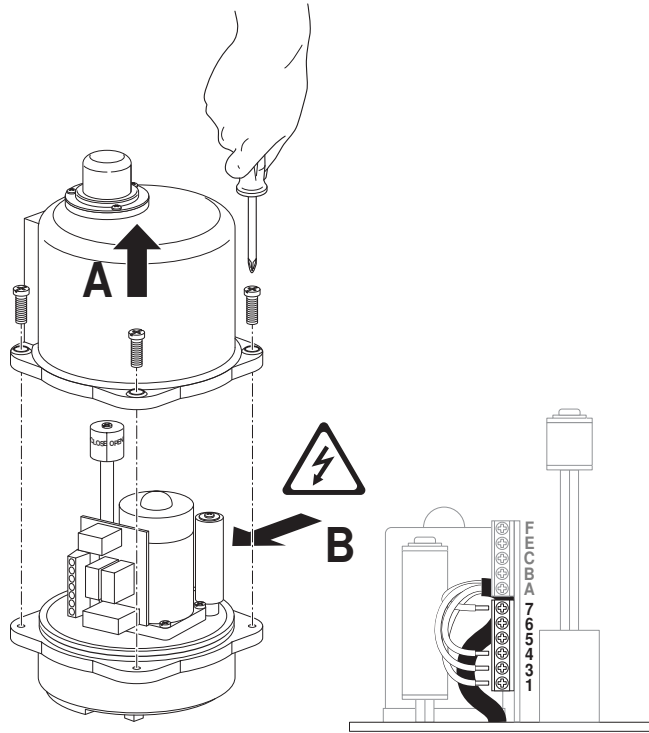

AC 24 V

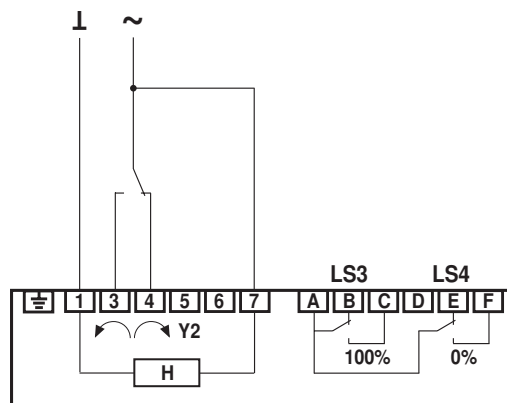

SY1-24-3-T

Y2 = 0%	LS3	LS4



AC 230 V

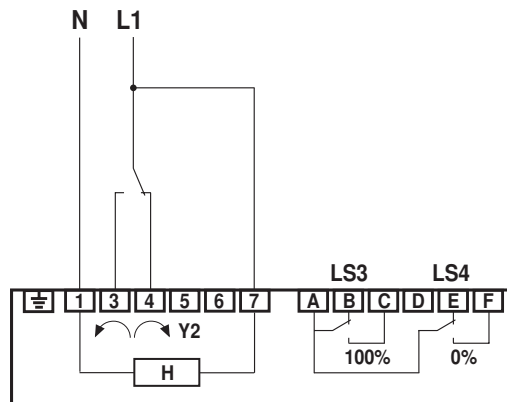

SY1-230-3-T