

GENERAL

The LION System (consisting of the CLLIONLC01 Controller Module and connected LION Panel Bus or LONWORKS Bus Input/Output Modules) provides highly cost-effective freely programmable control for heating, ventilation, and air conditioning (HVAC) systems. It performs a wide range of energy management functions, including optimum start/stop, night purge, and max. load demand. The LION System provides excellent value during installation and long-term operation. The modular design enables the system to be expanded to meet growing needs.

The LION System operates via "plug & play" Panel Bus I/O Modules, yielding huge installation and commissioning cost-savings due to new, patented technologies, while also operating with LONWORKS Bus I/O modules utilizing the LONWORKS communication standard.

The CLIOP830A mixed Panel Bus I/O module consists of a terminal socket with an integrated electronic module.

The pluggable (i.e., non-mixed) LION Panel Bus (CLIOP82x) and LONWORKS Bus (CLIOLx82x) I/O modules consist of a terminal socket and a removable electronic module, allowing the socket to be mounted and wired before the electronic module is installed. Such removable electronic modules can be changed without disrupting the power and bus connections: Software updates, configuration, and commissioning are all done automatically for all LION Panel Bus I/O Modules.

The open LONWORKS standard enables easy integration of 3rd-party controllers and devices, and communication with other CentraLine / Honeywell devices (e.g. SERVAL, Excel 10, and Excel 12 room controllers). Remote service can be done via a modem / ISDN adapter in connection with ARENA or SymmetrE building supervisors.

FEATURES

- Plug-and-play Panel Bus I/O Modules for easy maintenance
- LONWORKS Bus I/O Modules (FTT10-A, link power compatible) for easy integration into any system
- Pluggable I/O modules: I/O module exchange without rewiring the power and bus connections
- Reuseability of existing applications (Excel 500, etc.)
- Fast wiring with state-of-the-art push-in terminals (screw-type terminals also available) and bridge connectors
- Wide range of sensors supported (NTC20k Ω , NTC10k Ω , PT1000-1/-2, NI1000TK5000, PT3000, Balco500, 0/2...10 V, 0/4...20 mA). **NOTE:** The CLIOP830A mixed Panel Bus I/O module features inputs suitable for signals from NTC20k Ω sensors and 0/2...10 V, 0/4...20 mA, only.
- Binary input LEDs can be configured for status display (off/yellow) or alarm display (green / red) per channel. **NOTE:** The CLIOP830A mixed Panel Bus I/O module features only non-configurable binary input LEDs.
- Configurable safety position for outputs in case of loss of communication with the Controller module
- CLLIONLC01 Controller Module with real-time clock
- Max. wiring flexibility due to optional accessories like aux. terminals, manual disconnectors, and Cross-Connectors
- Can be mounted in small installation housings
- Flexible I/O module mix covering all your application requirements
- Utmost flexibility to design and control your most complex applications through increased memory size
- State-of-the-art control of critical applications thanks to short cycle times (30% faster than Excel 500 or PANTHER)
- Fast firmware download (~90 sec) via serial connection
- C-Bus to upgrade from and operate with existing C-Bus installations, thereby protecting your investment
- Dedicated modem interface for remote operation with SymmetrE
- Human-Machine-Interface, Laptop connection
- Separate installation of terminal sockets and electronic modules, thus lower risk of damage and theft in the construction phase

SYSTEM OVERVIEW

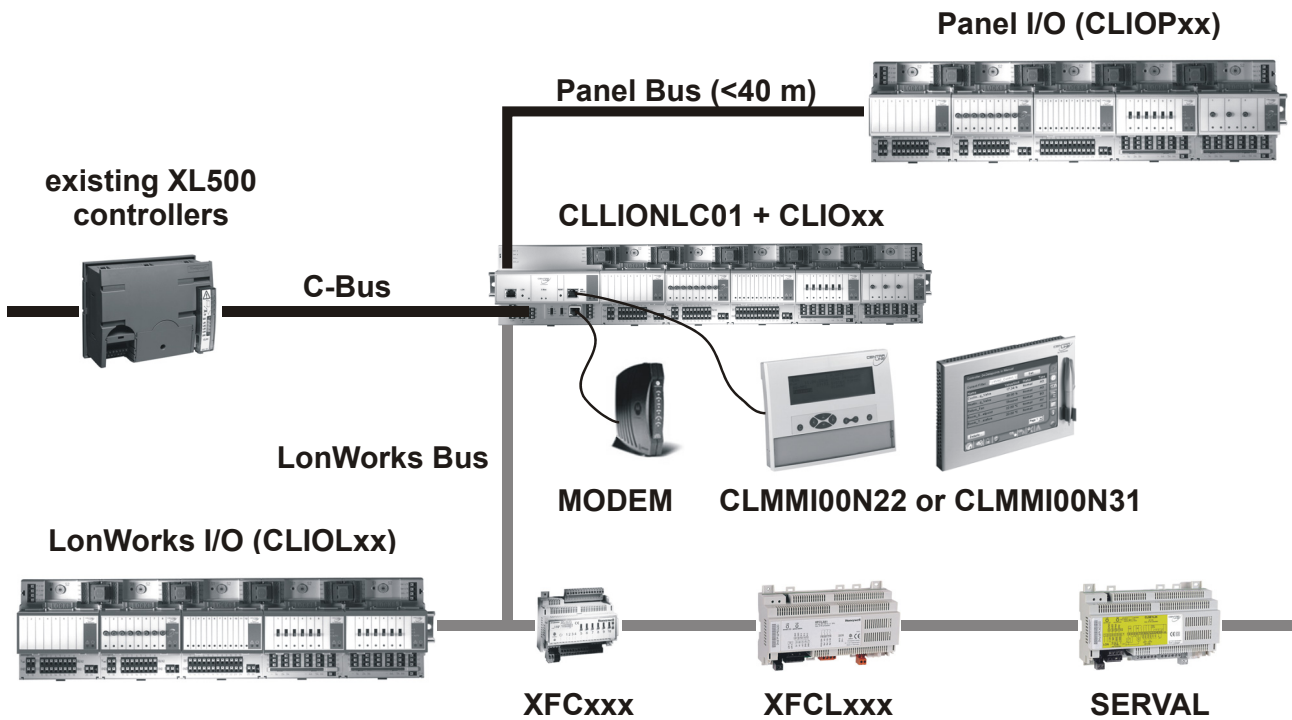

Fig. 1. System architecture (overview)

General

The LION Controller Module (CLLIONLC01) can communicate with a variety of other devices (see Fig. 4), including any combination of up to sixteen Panel I/O Modules and a large number of LONWORKS devices (e.g. room controllers), LONWORKS I/O Modules, and 3rd-party devices. The LION Panel Bus I/O Modules communicate via the Panel Bus, while the LION LONWORKS Bus I/O modules utilize the LONWORKS communication standard. The pluggable I/O modules consist of a terminal socket and a removable electronic module, allowing the socket to be mounted and wired before the electronic module is installed. All such electronic modules can be swapped out

without disrupting the power and bus connections: Simply unplug the "old" and insert the "new" module.

Software updates, configuration, and commissioning are all done automatically by the LION Controller Module for all Panel Bus I/O Modules.

The LION Panel Bus I/O Modules are addressed manually by adjusting their HEX switches.

The LION LONWORKS I/O Modules are configured using the COACH or CARE engineering tools. Alternatively, LonMaker and LNS plug-ins can also be used for configuration.

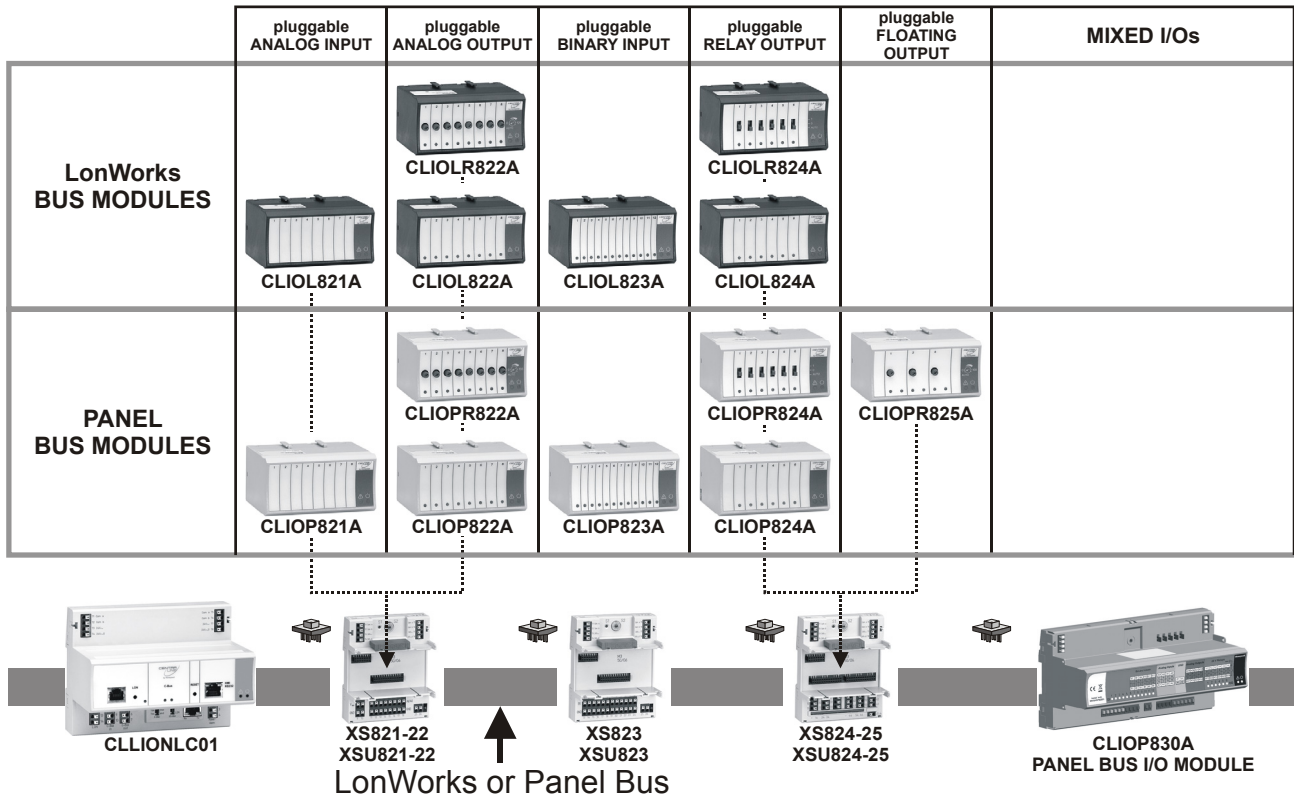









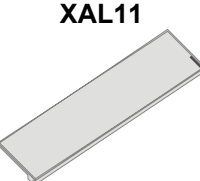

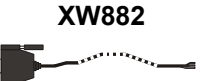
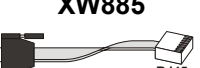

Fig. 2. Overview of LION Modules

Table 1. Overview of LION Modules

order number	description
CLLIONLC01	LION Controller Module
Panel Bus I/O Modules	
CLIOP821A	Pluggable Panel Bus Analog Input Module (with 8 analog inputs)
CLIOP822A	Pluggable Panel Bus Analog Output Module (with 8 analog outputs)
CLIOPR822A	Pluggable Panel Bus Analog Output Module (with 8 analog outputs and manual overrides)
CLIOP823A	Pluggable Panel Bus Binary Input Module (with 12 binary inputs)
CLIOP824A	Pluggable Panel Bus Relay Output Module (with 6 relay outputs)
CLIOPR824A	Pluggable Panel Bus Relay Output Module (with 6 relay outputs and manual overrides)
CLIOPR825A	Pluggable Panel Bus Floating Output Module (with 3 floating outputs and manual overrides)
CLIOP830A	Mixed Panel Bus I/O Module (with 8 analog inputs, 8 analog outputs, 12 binary inputs, and 6 relay outputs)
LonWorks Bus I/O Modules	
CLIOL821A	Pluggable LONWORKS Bus Analog input module (with 8 analog inputs)
CLIOL822A	Pluggable LONWORKS Bus Analog Output Module (with 8 analog outputs)
CLIOLR822A	Pluggable LONWORKS Bus Analog Output Module (with 8 analog outputs and manual overrides)
CLIOL823A	Pluggable LONWORKS Bus Binary Input Module (with 12 binary inputs)
CLIOL824A	Pluggable LONWORKS Bus Relay Output Module (with 6 relay outputs)
CLIOLR824A	Pluggable LONWORKS Bus Relay Output Module (with 6 relay outputs and manual overrides)
Terminal Sockets (not needed for CLIOP830A mixed Panel Bus I/O module)	
XS821-22	Push-in terminal socket for pluggable AI/AO modules (incl. connector bridge, swivel label)
XSU821-22	Screw-type terminal socket for pluggable AI/AO modules (incl. connector bridge, swivel label)
XS823	Push-in terminal socket for pluggable BI modules (incl. connector bridge, swivel label)
XSU823	Screw-type terminal socket for pluggable BI modules (incl. connector bridge, swivel label)
XS824-25	Push-in terminal socket for pluggable relay/floating output modules (incl. connector bridge, cross connector, swivel label)
XSU824-25	Screw-type terminal socket for pluggable relay/floating output modules (incl. connector bridge, cross connector, swivel label)

Table 2. Overview of auxiliary parts and spare parts

order number	description
 <p>XS812</p>	<p>Manual Disconnecter Module for AI/AO/BI Modules (for manual disconnection of individual signals; useful during start-up). Plugged between Terminal Socket and Electronic Module. For pluggable I/O modules, only.</p>
 <p>XS812RO</p>	<p>Manual Disconnecter Module for Relay Output Modules (for manual disconnection of individual signals; useful during start-up). Plugged between Terminal Socket and Electronic Module. Not suitable for line voltage. For pluggable I/O modules, only.</p>
 <p>XS814</p>	<p>Ten Auxiliary Terminal Blocks (for distribution of signals/power). Each terminal block includes two groups with seven internally-connected push-in terminals. For pluggable I/O modules, only.</p>
 <p>XS830</p>	<p>Ten Auxiliary Terminal Blocks (for distribution of signals/power). Each terminal block consists of two groups of nine internally-connected push-in terminals. For CLIOP830A, only.</p>
 <p>XS831</p>	<p>Ten Auxiliary Terminal Blocks (for connection of 0...20 mA signals). Each terminal block supports up to 8 current inputs. For CLIOP830A, only.</p>
 <p>XS815</p>	<p>20 Cross-Connectors for connection of six relay commons. One Cross-Connector is included in the Terminal Socket package. For pluggable I/O modules, only.</p>
 <p>XS817</p>	<p>40 Cross-Connectors for connection of three relay commons (if voltage in relay block 1 is different from voltage in relay block 2). For pluggable I/O modules, only.</p>
 <p>XS816</p>	<p>10 Bridge Connectors. One Bridge Connector is included in the Terminal Socket package / in the CLIOP830A mixed Panel Bus I/O module package.</p>
 <p>XAL10</p>	<p>10 Swivel Labels (for attaching the application-specific label printed with CARE). One Swivel Label is included in the Terminal Socket package.</p>
 <p>XAL11</p>	<p>10 Swivel Label Holders for Mixed I/O modules. One Swivel Label Holder is included in each mixed I/O module package. For mixed I/O modules, only.</p>
 <p>XW586</p>	<p>Modem cable for LION.</p>
 <p>XW882</p>	<p>Adapter cable for CLMMI00N22 Operator Interface (alternatively, XW586 + XW582 can be used).</p>
 <p>XW885</p>	<p>Download cable (alternatively, XW586 + XW585 can be used).</p>

NOTE: All LION I/O Modules are protected against short circuit, 24 V~ +20% and 30 Vdc

Table 3. Pluggable LION I/O Module specifications

Module	Analog Input	Analog Output	Binary Input	Relay Output	Floating Output
Panel	CLIOP821A	CLIOP822A, CLIOPR822A	CLIOP823A	CLIOP824A, CLIOPR824A	CLIOPR825A
LONWORKS	CLIOL821A	CLIOL822A, CLIOLR822A	CLIOL823A	CLIOL824A, CLIOLR824A	
no. of I/Os	8 analog inputs	8 analog outputs	12 binary inputs	6 relay outputs	3 floating outputs
characteristic	<p>Linear Graph 0..10 Vdc with pull-up, 0(2)...10 Vdc without pull-up</p> <p><u>NTC20kΩ (-50...+150 °C, default)</u></p> <p><u>NTC10kΩ (-30...+100 °C)</u></p> <p>PT₁₀₀₀₋₁ (-50...150°C)</p> <p>PT₁₀₀₀₋₂ (0...400°C)</p> <p>NI1000TK5000 (-30...+130 °C)</p> <p>PT₃₀₀₀ (-50...150°C)</p> <p>BALCO₅₀₀ (-30...120°C)</p> <p>Also configurable as: binary inputs</p> <ul style="list-style-type: none"> ▪ Linear graph (0...10 V with pull-up) <p>Features:</p> <ul style="list-style-type: none"> ▪ 16-bit resolution ▪ configurable offset per input ▪ auxiliary voltage: 10 Vdc, I_{max} = 5 mA 	<p>0...11 Vdc / \pm 1 mA, <u>8-bit resolution (default)</u></p> <p>Also configurable as: floating outputs or binary outputs (0 V / 10 V)</p> <p>Features:</p> <ul style="list-style-type: none"> ▪ 8-bit resolution ▪ Safety position (remain, 0%, 50%, 100%) ▪ red LED per output ▪ light intensity follows output level in auto <p>Version with manual override (R):</p> <ul style="list-style-type: none"> ▪ 1 potentiometer per output ▪ auto feedback signal (mode + value) ▪ blinking in manual override position 	<p><u>static binary input (default: dry contact)</u></p> <p>Also configurable as: totalizers (20 Hz)</p> <p>Features:</p> <ul style="list-style-type: none"> ▪ 1 LED per input ▪ Color mode can be set per input to OFF/yellow or green/red using CARE 	<p>relay outputs (default)</p> <p>Features:</p> <ul style="list-style-type: none"> ▪ Changeover relays ▪ Voltage: 19...250 V~, 1...29 Vdc, P>50 mW ▪ max. total current: 12 A ▪ current per relay: N.O.: 4(4) A~ or 4(1) A=, N.C.: 2(1) A~ or 4(1) A= ▪ Safety position (remain, 0%, 100%) ▪ yellow LED per output <p>Version with manual override (R):</p> <ul style="list-style-type: none"> ▪ 1 switch per output ▪ auto feedback signal (mode + value) ▪ blinking in manual override position 	<p><u>floating outputs</u></p> <p>Features:</p> <ul style="list-style-type: none"> ▪ 2 relays per floating output ▪ Voltage: 19...250 V~, 1...29 Vdc, P>50 mW ▪ max. total current: 12 A ▪ current per relay: N.O.: 4(4) A~ or 4(1) A=, N.C.: 2(1) A~ or 4(1) A= ▪ 1 potentiometer per floating output ▪ 2 LEDs per output: green: relay 1 closed, red: relay 2 closed ▪ blinking in manual override position ▪ auto feedback signal (mode + value)

Table 4. Mixed LION Panel Bus I/O module specifications

Module	Analog Inputs	Analog Outputs	Binary Inputs	Relay Outputs
CLIOP830A	<p>Number: 8</p> <p>Characteristics: Linear Graph 0..10 Vdc with pull-up, 0(2)...10 Vdc without pull-up</p> <p><u>NTC20kΩ (-30...+110 °C, default)</u></p> <p>Features:</p> <ul style="list-style-type: none"> ▪ 10-bit resolution ▪ configurable offset per input 	<p>Number: 8</p> <p>Characteristics: 0...11 Vdc / \pm 1 mA, <u>default</u></p> <p>Also configurable as: binary outputs (0 V / 10 V)</p> <p>Features:</p> <ul style="list-style-type: none"> ▪ 10-bit resolution (default) ▪ Safety position (remain, 0%, 50%, 100%) 	<p>Number: 12</p> <p>Characteristics: <u>static binary input (default: dry contact)</u></p> <p>ON: < 1.6 kΩ OFF: > 90 kΩ</p> <p>Also configurable as: totalizers (15 Hz)</p> <p>Features:</p> <ul style="list-style-type: none"> ▪ 1 yellow LED per input 	<p>Number: 6</p> <p>Characteristics: <u>relay outputs (default)</u></p> <p>Features:</p> <ul style="list-style-type: none"> ▪ Voltage: 24 Vac/dc, P>50 mW ▪ max. total current: 3 A (ac or dc) ▪ current per relay: 500 mA ▪ normally-open contacts: P > 50 mW, voltage: 24 V (ac or dc) ▪ yellow LED per output

CLLIONLC01 CONTROLLER MODULE

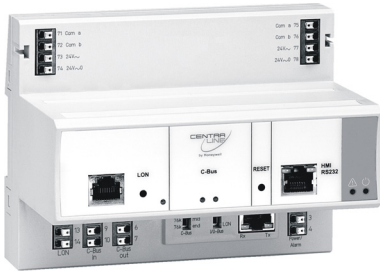

Fig. 3. CLLIONLC01 Controller Module

The CLLIONLC01 Controller Module can communicate with a variety of other devices (see Fig. 4), including any combination of up to sixteen Panel I/O Modules and/or LONWORKS devices (e.g. room controllers).

A total of 381 data-points (of all types, e.g. internal virtual data-points and hardware data-points) are permitted. Typically, HVAC applications require an equal number of internal virtual data-points and hardware data-points.

Up to 40 m distance between the CLLIONLC01 and the Panel I/O Modules is permitted.

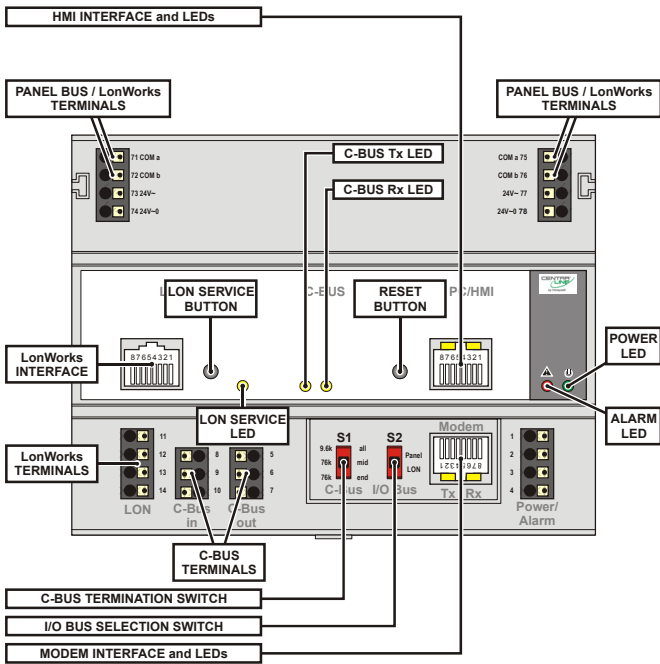

Fig. 4. CLLIONLC01 Controller Module features

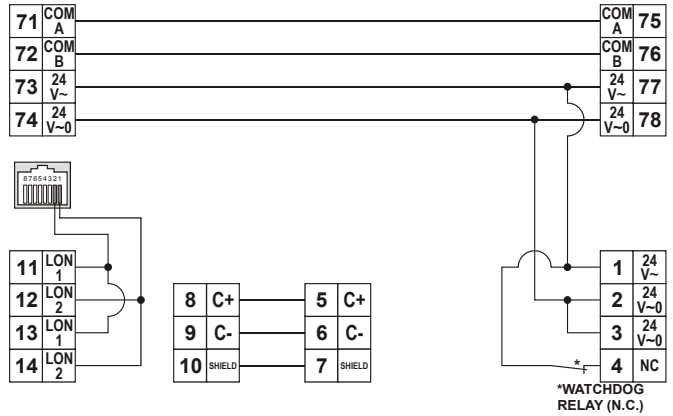

Fig. 5. CLLIONLC01, terminal assignment

Electrical Specifications

Operating Voltage

24 Vac, ± 20%, 21...30 Vdc

The LION System (CLLIONLC01 Controller Module and connected LION I/O Modules together with field devices) can be powered by one or more external transformers.

Memory

- 128 kB EPROM
- 512 kB RAM
- 2 MB Flash EPROM (firmware and application)

Watchdog

The watchdog output is active if the LION Controller Module is not operating properly.

Microprocessor

16-bit processor (TMP 91 CY22). 22 MHz

Memory and Real-Time Clock Backup

In case of power failure, the super capacitor saves RAM content and real-time clock for 72 hours (environmentally friendly; no problems disposing of dead batteries).

CLMMI00N22 OPERATOR INTERFACE

The CLLIONLC01 can be connected with a CLMMI00N22 Operator Interface or PC-based XL-Online operator and service software.



Fig. 6. The CLMMI00N22 Operator Interface

The CLMMI00N22 Operator Interface is the command and information center of the LION System. With it, data can be entered and displayed. Information such as current temperature values, control status, etc. can also be displayed. The menu-driven, 6-line, backlit LCD graphic display with 34 characters per line, together with eight clearly marked keys, makes the device easy to use.

The CLMMI00N22 is connected to the HMI Interface on the front of the LION Controller Module. The CLMMI00N22 can be mounted up to 15 m away from the controller. This can be extended to 100 m using line drivers.



Fig. 7. The CLMMI00N31 Operator Interface

CLMMI00N31 OPERATOR INTERFACE

The CLMMI00N31 Operator Interface is an easy-to-operate and robust operator unit for the entire EXCEL 5000 range of plant controllers.

The touch-panel operation screens allow for easy and self-explanatory operation by finger-tip or by touch-pen (supplied). User-configurable fast-access lists can contain selected datapoints, time programs, and parameters, thus permitting plant-oriented and customer-oriented operation.

The CLMMI00N31 can be connected to the HMI interface of the CLLIONLC01 Controller Module using either an XW882 cable or an XW586 cable together with an XW585 cable. Graphic trending of datapoints is supported.

XL-ONLINE

The PC-based XL-Online is the local intelligent operating and service software. It performs all the operating functions of the CLMMI00N22 as well as having the advantages of a PC. Not only can the XL-Online make major modifications such as changing setpoint values and time program switching points, it also offers all service and commissioning functions.

XL-Online can be operated at five different access levels, three of which are password-protected. A printer can be connected to the parallel interface of the PC to log alarms and error messages. As with the CLMMI00N22, the PC with the XL-Online operator and service software can be placed up to 15 meters from the computer module. Line drivers allow distances of up to 100 m.

Communication Human-Machine Interface

The CLLIONLC01 Controller Module is equipped with an HMI Interface (RJ45 socket serving as a serial port) for the connection of HMIs, e.g.:

- the CLMMI00N22 or the CLMMI00N31, or
- a laptop (with XL-Online / CARE).

C-Bus Interface

Up to 30 C-bus devices (e.g. controllers, etc.) can communicate with one another and a PC central via the C-bus interface. The C-bus must be connected through the individual controllers (open ring topology).

LONWORKS Interface

The LONWORKS bus is a 78-kilobit serial link that uses transformer isolation so that the bus wiring does not have a polarity; that is, it is not important which of the two LONWORKS bus terminals are connected to each wire of the twisted pair. The LONWORKS bus can be wired in daisy chain, star, loop or any combination thereof as long as the max. wire length requirements are met. The recommended configuration is a daisy chain with two bus terminations. This layout allows for max. LONWORKS bus length, and its simple structure presents the least number of possible problems, particularly when adding on to an existing bus.

Modem Interface

The CLLIONLC01 Controller Module is equipped with a Modem Interface (RJ45 socket serving as a serial port) for the connection of a modem or an ISDN terminal adapter used with SymmetrE.

Optionally, LION Systems can also be connected to an ARENA using the iLION on the LONWORKS bus for modem or TCP/IP connection.

Panel Bus Interface

The CLLIONLC01 Controller Module features a panel bus interface (max. 40 m), polarity-insensitive for easy wiring. Deterministic bus (cycle time: 250 ms to scan all connected Panel I/O Bus Modules).

PROGRAMMING

The LION System can be programmed using the "CARE" software package, which is especially designed to meet the requirements of application engineers. The easy-to-use, menu-driven software package includes the following functions:

- data point description,
- time program,
- alarm handling,
- application program (DDC program),
- password protection,
- LONWORKS configuration.

Programming is also possible using the COACH software (starting with COACH version 2.02).

Data Point Description

Data points are the basis of the LION System. They contain system-specific information such as values, status, limit values, and default settings. The user has easy access to data points and the information that they contain. The user can recall and modify information in the data points.

Time Program

The time program can be used to enter the setpoint or status at any time for any data point. The following time programs are available:

- daily program,
- weekly program,
- annual program,
- TODAY function,
- special day list.

Daily programs are used to create a weekly program. The annual program is created automatically by multiplying the weekly program and then incorporating daily programs. The TODAY function allows direct changes to the switching program. It allows you to allocate a setpoint or status to the selected data point for a defined period of time.

Alarm Handling

The alarm handling facility offers system security. Alarm signals can, for example, alert the operator to scheduled maintenance work. All alarms that occur are stored in data files and reported immediately. If your system configuration allows, you can also list alarms on a printer or transmit alarms to higher-level devices via the local bus or a modem.

There are two types of alarms, critical and non-critical. Critical alarms (e.g. system alarms caused by communication failures) have priority over non-critical alarms. To distinguish between alarm types, you can generate your own alarm messages or use pre-programmed system messages. The following events all generate alarm messages:

- exceeding limit values,
- overdue maintenance work,
- totalizer readings,
- digital data point changes of state.

The alarm buffer can contain up to 99 alarms.

Application Program (DDC program)

You can use the CentralLine CARE programming tool to create application programs for your system. A set of predefined applications (MODAL) is available in order to provide state-of-the-art applications without the need of programming.

Password Protection

The control system is also protected by passwords. This ensures that only authorized persons have access to system data. There are four operator levels, each protected by its own password.

Operator level 1: Read only. The operator can display information about setpoints, switching points, and operating hours.

Operator level 2: Read and make limited changes. The operator can display system information and modify certain pre-set values.

Operator level 3: Read and make changes. System information can be displayed and modified.

Operator level 4: Access level for tools (e.g. CARE, XL-Online).

Trending

The LION System provides controller-based trending. This feature allows historical values to be stored in the controller. Both time-based or value-hysteresis-based trending are possible.

LION I/O MODULES

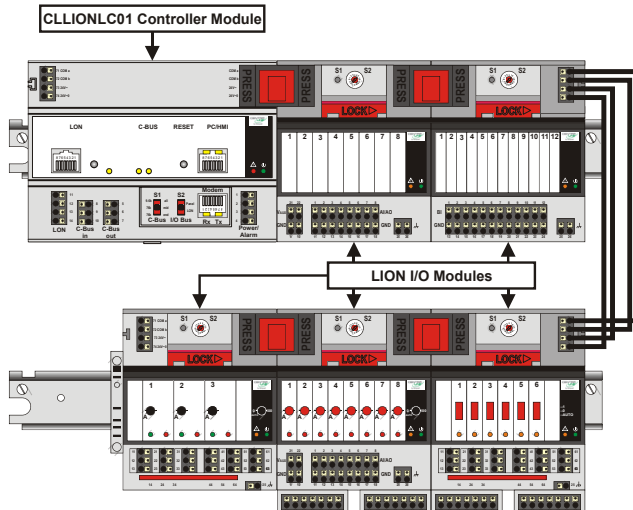

Fig. 8. LION Controller and I/O Modules on DIN rails

General

Each LION I/O Module is equipped with:

- one green power LED
- one yellow status LED

Overvoltage Protection

All inputs and outputs are protected against 24 Vac and 40 Vdc overvoltage as well as against short-circuiting.

Service LED

Each I/O Module is equipped with a yellow service LED for easy diagnosis of failures.

Microprocessor

Each I/O Module is equipped with its own microprocessor.

Panel Bus I/O Modules

Up to 16 Panel I/O modules in any I/O mixture may be connected.

Addressing is performed using the HEX switch located on each terminal socket.

The LION Controller Module and Panel I/O modules can be separated by up to 40 m. Firmware maintenance is automatically handled by the CLLIONLC01.

LonWorks Bus I/O Modules

The LONWORKS Bus I/O Modules can be used with any LONWORKS controller.

In addition to the main microprocessor, the LONWORKS Bus I/O Modules also have their own Neuron chip (3120). Each LonWorks I/O Module is equipped with an FTT-10A transceiver (linki power compatible).

A LONWORKS service button is located on each terminal socket.

Analog Input Modules

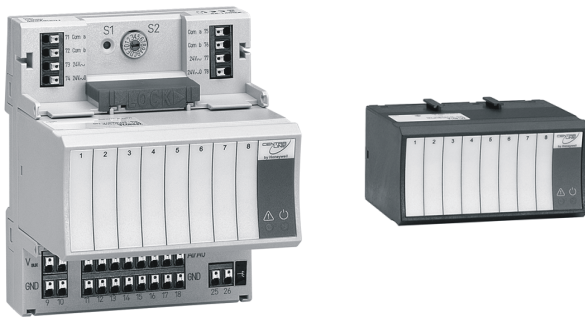

Fig. 9. CLIO821A Panel Bus AI Module (shown with socket) and CLIO821A LonWorks Bus AI Module (shown without socket)

The pluggable LION Analog Input Modules, with 8 analog inputs, are available in the following versions:

- CLIO821A Panel Bus Analog Input Module
- CLIO821A LonWorks Bus Analog Input Module

They are installed with the XS821-22 or XSU821-22 Terminal Socket (incl. one connector bridge and one swivel label).

Accessory disconnecter module: XS812 (see also Table 2 on page 4).

Features

- 0...10 Vdc, 2...10 Vdc without pull-up
- 0...10 Vdc with pull-up (linear graph, e.g. used for wall module connection)
- 0/4...20 mA, needs 499 Ω resistor in parallel
- NTC20kΩ (-50...+150 °C, default)
- NTC10kΩ (-30...+100 °C)
- PT1000-1 (-50...+150 °C)
- PT1000-2 (0...+400 °C)
- NI1000TK5000 (-30...+130 °C)
- PT3000 (-50...+150 °C)
- BALCO500 (-30...+120 °C)
- Binary input
- 16-bit resolution
- Configurable offset per input
- Auxiliary voltage: 10 Vdc, $I_{MAX} = 5 \text{ mA}$
- Sensor failure detection

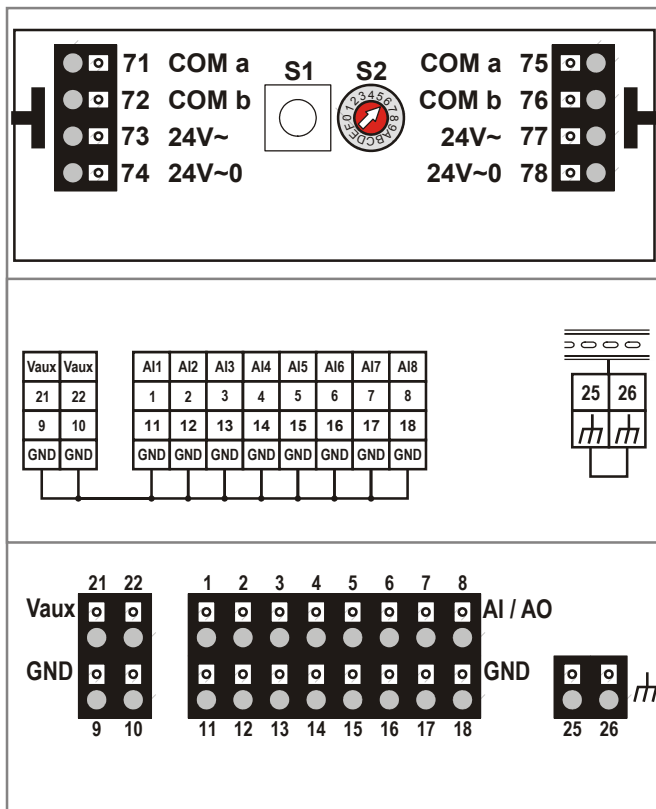

Fig. 10. LION Analog Input Modules (schematic)

Analog Output Modules

CLIOP822A



CLIOL822A



Fig. 11. CLIOP822A Panel Bus AO Module and CLIOL822A LonWorks Bus AO Module (both shown without socket)



Fig. 12. CLIOPR822A Panel Bus AO Module (shown with socket) and CLIOLR822A LonWorks Bus AO Module (shown without socket)

The pluggable LION Analog Output Modules, with 8 analog outputs, are available in the following versions:

- CLIOP822A Panel Bus Analog Output Module (without manual overrides)
- CLIOPR822A Panel Bus Analog Output Module (with manual overrides)
- CLIOL822A LONWORKS Bus Analog Output Module (without manual overrides)
- CLIOLR822A LONWORKS Bus Analog Output Module (with manual overrides)

They are installed with the XS821-22 or XSU821-22 Terminal Socket (incl. one connector bridge and one swivel label).

Accessory disconnector module: XS812 (see also Table 2 on page 4).

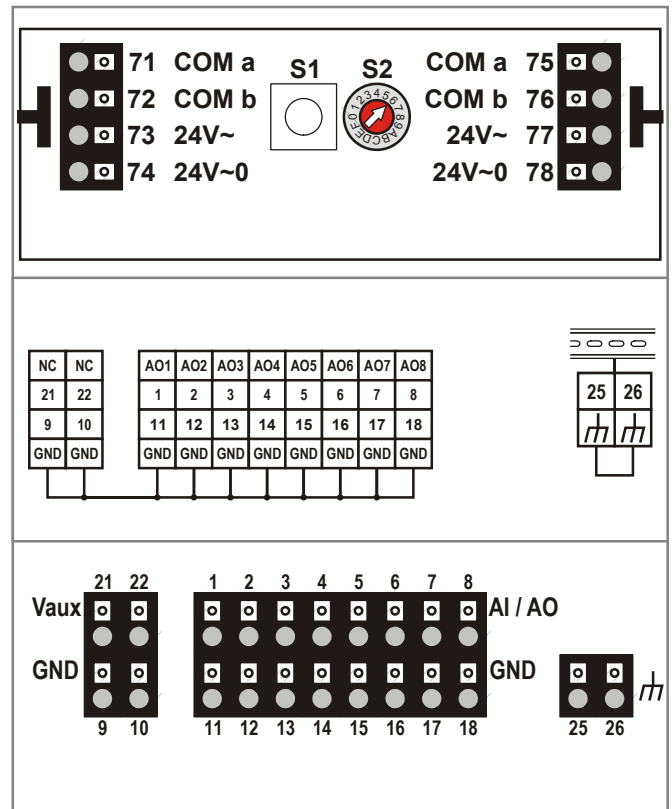

Fig. 13. LION Analog Output Modules (schematic)

Features

- 0...11 Vdc, +/- 1 mA
- Floating actuator (requires MCD3)
- Binary output (0 V / 10 V)
- red LED per output (brightness according to signal level)
- Optional versions with manual override potentiometers (Auto, 0...100%; LED flashes in override mode)
- Feedback on manual override signal
- 8-bit resolution
- Configurable safety position for outputs in case of communication problems (remain, 0%, 50%, 100%)

Binary Input Modules



Fig. 14. CLIO823A Panel Bus BI Module (shown with XS823) and CLIOL823A LonWorks Bus BI Module (shown without socket)

Features

- Static binary input (dry contact)
- Totalizer for up to 20 Hz
- LEDs per binary input supporting alarm display mode (red/green) or status mode (off/yellow).
- Color mode of each LED can be set to OFF/yellow or green/red in CARE.

The pluggable LION Binary Input Modules, with 12 binary inputs, are available in the following versions:

- CLIO823A Panel Bus Binary Input Module
- CLIOL823A LONWORKS Bus Binary Input Module

They are installed with the XS823 or XSU823 Terminal Socket (incl. one connector bridge and one swivel label).

Accessory disconnecter module: XS812 (see also Table 2 on page 4).

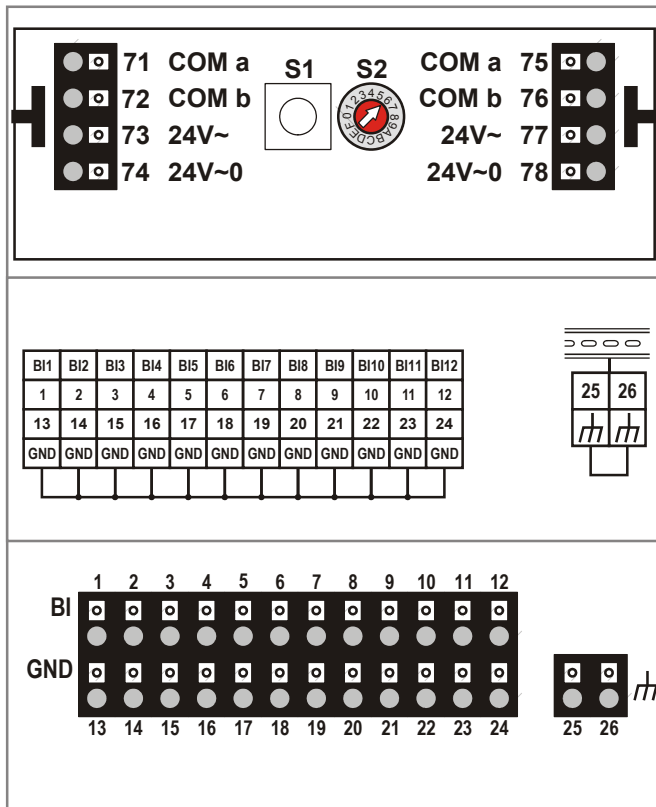

Fig. 15. LION Binary Input Modules (schematic)

Relay Output Modules

CLIOP824A



CLIOL824A



Fig. 16. CLIOP824A Panel Bus Relay Output Module and CLIOL824A LonWorks Bus Relay Output Module (both shown without socket)



Fig. 17. CLIOPR824A Panel Bus Relay Output Module (shown with socket) and CLIOLR824A LonWorks Bus Relay Output Module (shown without socket)

The pluggable LION Relay Output Modules, with 6 relay outputs, are available in the following versions:

- CLIOP824A Panel Bus Relay Output Module (without manual overrides)
- CLIOPR824A Panel Bus Relay Output Module (with manual overrides)
- CLIOL824A LONWORKS Bus Relay Output Module (without manual overrides)
- CLIOLR824A LONWORKS Bus Relay Output Module (with manual overrides)

They are installed with the XS824-25 or XSU824-25 Terminal Socket (incl. one connector bridge, one cross connector, and one swivel label).

Accessory disconnector module: XS812-RO (see also Table 2 on page 4).

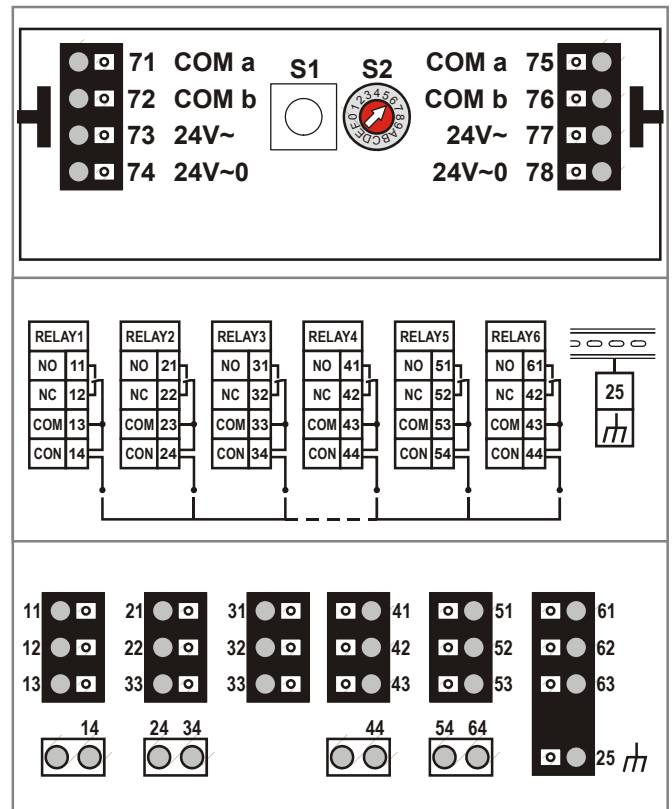

Fig. 18. LION Relay Output Modules (schematic)

Features

- Cross-Connector
- 1 yellow LED per output
- Optional versions with manual override switches (Auto, 0, 1; LED flashes in override mode)
- Feedback on manual override signal
- Configurable safety position for outputs in case of communications problems (remain, OFF, ON)
- Permissible Load per Relay Output Module (Total)
 - *Max. load:*
 - 19...250 Vac: 12 A
 - 1...24 Vdc: 12 A resistive, 3 A inductive
- Permissible Load per Normally-Open Contact:
 - *Max. load:*
 - 19...250 Vac: 4 A resistive or inductive
 - 1...24 Vdc: 4 A resistive, 1 A inductive
 - *Min. load:* P > 50 mW
- Permissible Load per Normally-Closed Contact:
 - *Max. load:*
 - 19...250 Vac: 2 A resistive, 1 A inductive
 - 1...24 Vdc: 2 A resistive, 1 A inductive
 - *Min. load:* P > 50 mW

Floating Output Module



Fig. 19. CLIOPR825A Panel Bus Floating Output Module (shown with socket)

The pluggable CLIOPR825A Panel Bus Floating Output Module (with manual overrides), with 3 floating outputs, is installed with the XS824-25 or XSU824-25 Terminal Socket (incl. one connector bridge, one cross connector, and one swivel label).

Accessory disconnector module: XS812-RO (see also Table 2 on page 4).

Features

- Cross-Connector
- 1 red LED (opening) and 1 green LED (closing) per floating output
- Manual override potentiometers (Auto, 0%...100%; LED flashes in override mode)
- Feedback on manual override signal
- Configurable safety position for outputs in case of communication problems (remain, 0%, 50%, 100%)
- Permissible Load per Floating Output Module (Total)
 - *Max. load:*
 - 19...250 Vac: 12 A
 - 1...24 Vdc: 12 A resistive, 3 A inductive
- Permissible Load per Normally-Open Contact:
 - *Max. load:*
 - 19...250 Vac: 4 A resistive or inductive
 - 1...24 Vdc: 4 A resistive, 1 A inductive
 - *Min. load:* P > 50 mW
- Permissible Load per Normally-Closed Contact:
 - *Max. load:*
 - 19...250 Vac: 2 A resistive, 1 A inductive
 - 1...24 Vdc: 2 A resistive, 1 A inductive
 - *Min. load:* P > 50 mW

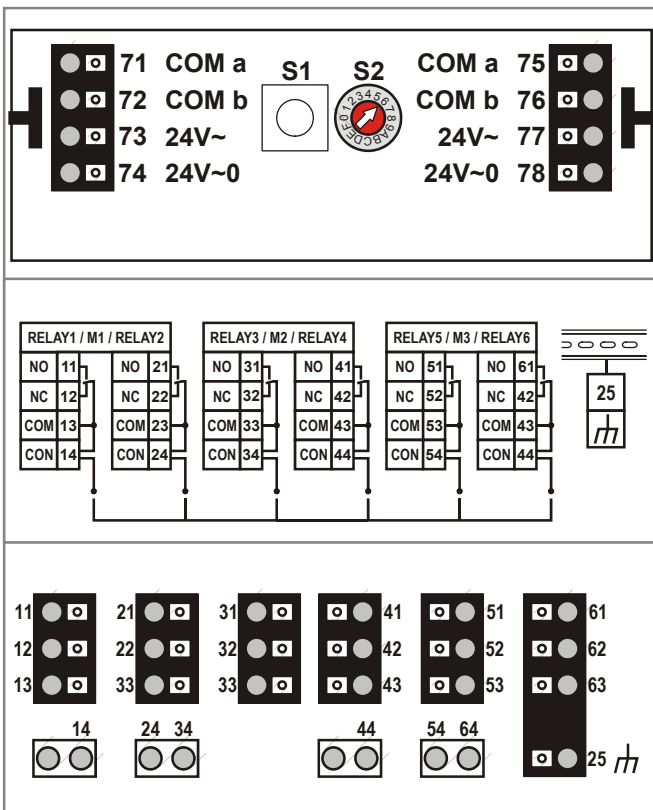

Fig. 20. CLIOPR825A Panel Bus Floating Output Module (schematic)

Mixed I/O Modules

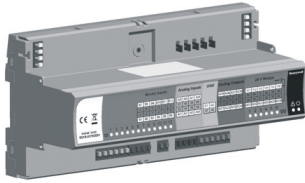

Fig. 21. CLIOP830A Mixed Panel Bus Module

The CLIOP830A mixed Panel Bus I/O module, with 8 analog inputs, 8 analog outputs, 12 binary inputs, and 6 relay outputs, is equipped with push-in terminals.

It features an integrated terminal socket and electronic module and comes complete with one connector bridge and one swivel label.

The CLIOP830A can be equipped with up to two rows of (XS830 and/or XS831) auxiliary terminal blocks on the top and/or bottom.

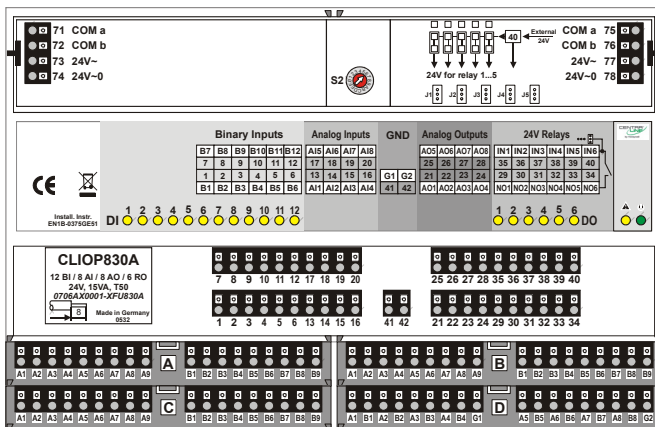

Fig. 22. CLIOP830A mixed Panel Bus I/O module, shown with 4 optional aux. terminal blocks (top view)

Features

- 1 yellow LED per output
- Configurable safety position for outputs in case of communications problems (remain in last position, OFF, ON)
- Permissible Load per mixed Panel Bus I/O module (total)
 - *Max. load:*
 - 19...29 Vac: 3 A
 - 1...24 Vdc: 3 A resistive, 3 A inductive
- Permissible Load per Normally-Open Contact:
 - *Max. load:*
 - 19...29 Vac: 0.5 A resistive or inductive
 - 1...24 Vdc: 0.5 A resistive, 1 A inductive
 - *Min. load:* P > 50 mW

Environmental Specifications

Ambient Temperature

Operation: 0...50 °C (32...122 °F)

Storage: -20...+70 °C (-4...+158 °F)

Ambient Humidity (Operation and Storage)

5 to 93% r.h. non-condensing

Table 5. Power consumption of CLLIONLC01

devices powered	supply voltage	
	24 Vac	24 Vdc
CLLIONLC01*	190 mA	140 mA
watchdog load (terminal 4)	< 500 mA	< 500 mA
CLIOP821A, CLIOL821A	130 mA	80 mA
CLIOP822A, CLIOPR822A	150 mA	90 mA
CLIOL822A, CLIOLR822A	160 mA	90 mA
CLIOP823A, CLIOL823A	180 mA	130 mA
CLIOP824A, CLIOPR824A, CLIOPR825A	140 mA	80 mA
CLIOL824A, CLIOLR824A	140 mA	90 mA
CLIOP830A	200 mA	95 mA

Mechanical

Housing dimensions (H x W x D)

The CLLIONLC01 Controller Module has the dimensions: 110 X 144 X 93 mm (see also Fig. 23 on page 17).

The pluggable LION I/O Modules (mounted on Terminal Sockets) all have the dimensions: 110 X 90 X 93 mm (see also Fig. 24 on page 17).

Housing Material

Plastic, flame-retardant

Mounting Methods

DIN-rail mounting (e.g. in control cabinet).

Calculated Lifetime of Weakest Components

MTBF \geq 13.7 years (under typical operating conditions)

Protection Class

IP 20

Available Literature

- Mounting Instructions (EN1B-0359GE51);
- Installation Instructions (EN1B-0375GE51).

Norms, Standards

The LION System conforms to EN 60730-1:2005-12 and EN 60730-2-9:2005-10.

Dimensions

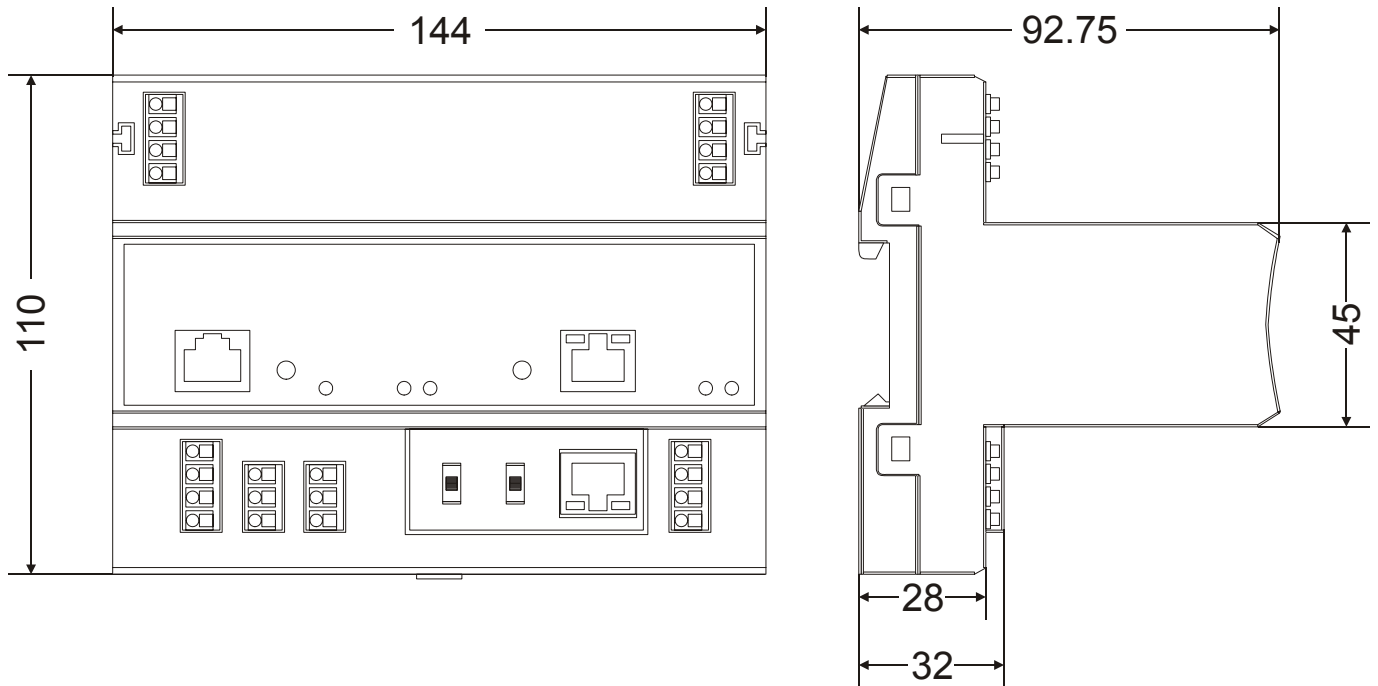

Fig. 23. CLLIONLC01 Controller Module, outside dimensions (in mm)

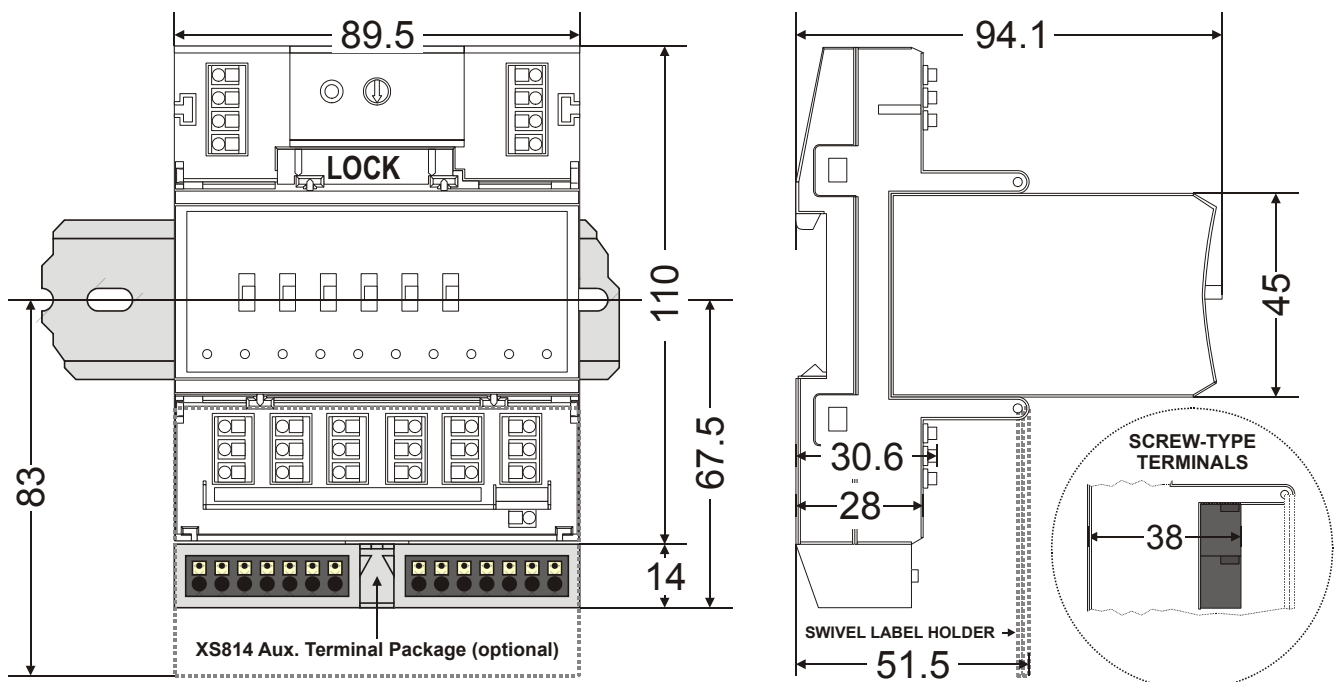

Fig. 24. LION I/O Modules (example shows Manual Overrides), incl. Terminal Socket, outside dimensions (in mm)

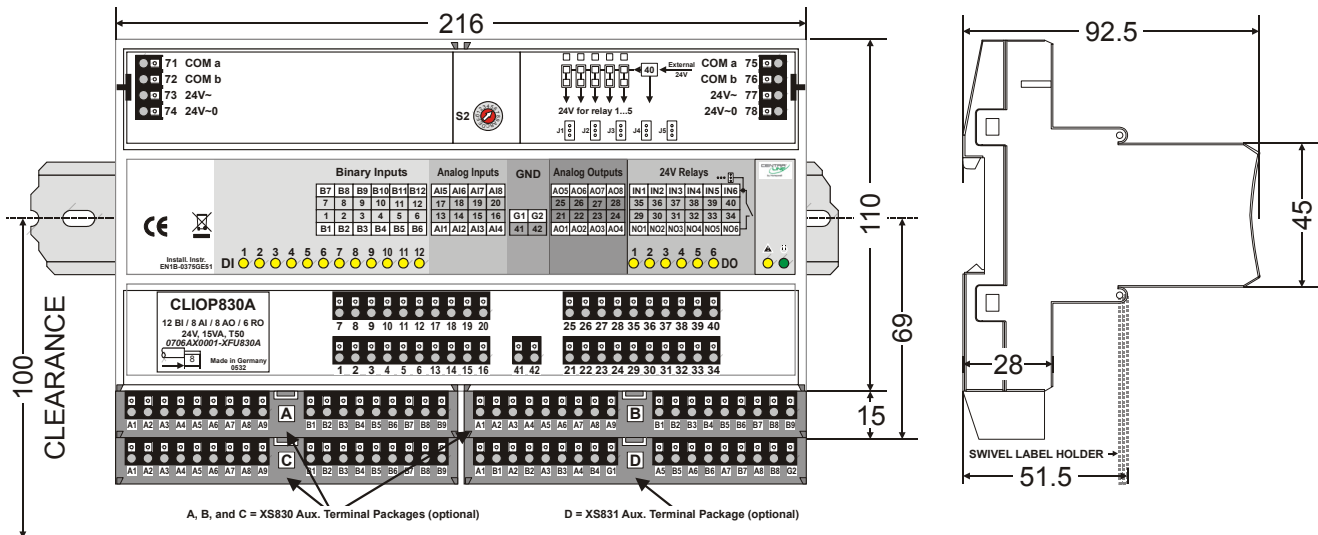

Fig. 25. CLIOP830A mixed Panel Bus I/O module (shown with 4 auxiliary terminal packages), dimensions (in mm)

Manufactured for and on behalf of the Environmental and Combustion Controls Division of Honeywell Technologies Sàrl, Rolle, Z.A. La Pièce 16, Switzerland by its Authorized Representative:

Centraline
 Honeywell GmbH
 Böblinger Strasse 17
 71101 Schönaich, Germany
 Tel +49 7031 637 845
 Fax +49 7031 637 846
info@centraline.com
www.centraline.com

Centraline
 Honeywell Control Systems Ltd.
 Arlington Business Park
 UK-Bracknell, Berkshire RG12 1EB
 Tel +44 13 44 656 565
 Fax +44 13 44 656 563
info-uk@centraline.com
www.centraline.com

Printed in Germany.
 Subject to change
 without notice.
 EN0Z-0921GE51 R0709

