

Mechanical pressure switches

Technical features / Advantages

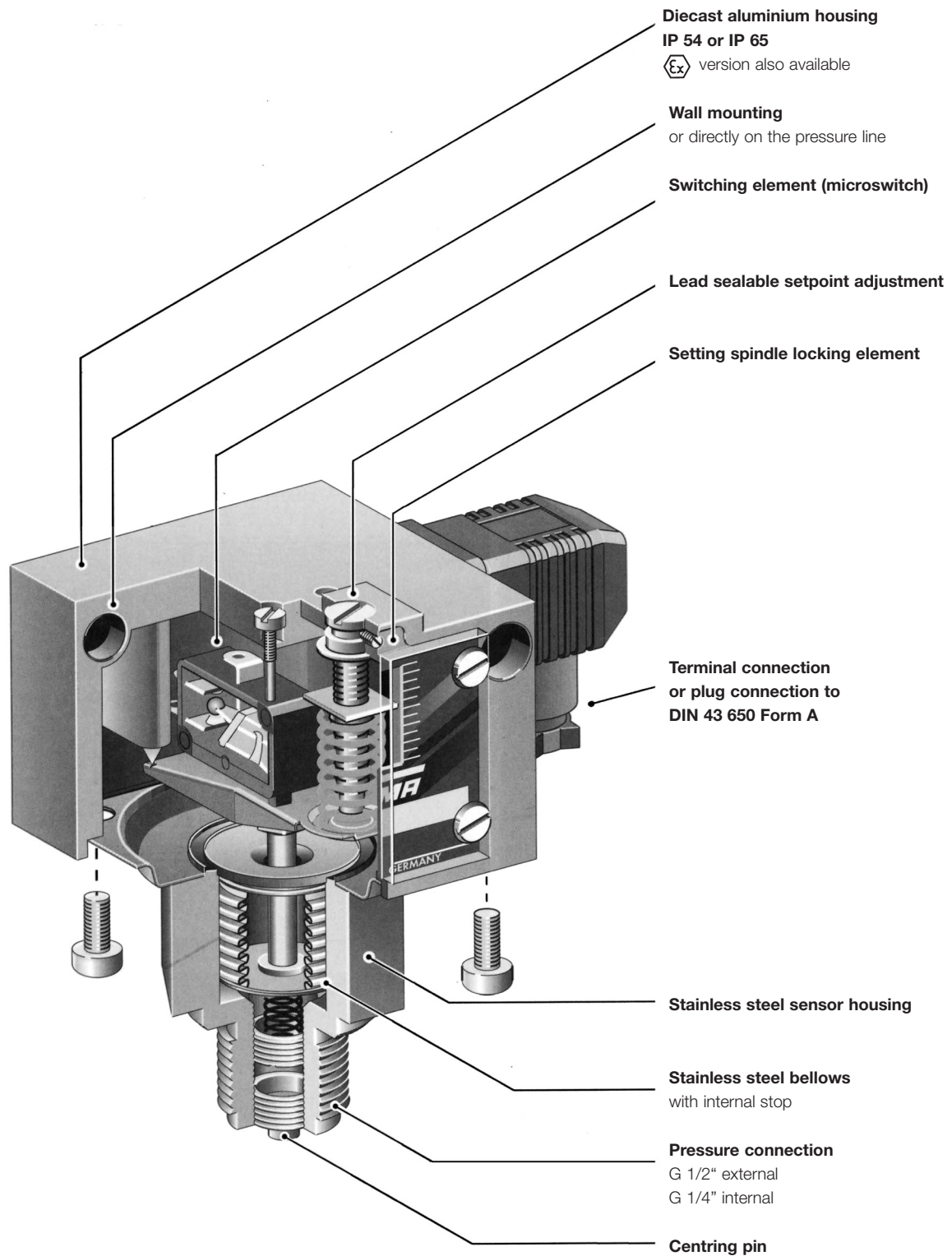

Pressure switches

General description

Operating mode

The pressure occurring in the sensor housing (1) acts on the measuring bellows (2). Changes in pressure lead to movements of the measuring bellows (2) which are transmitted via a thrust pin (4) to the connecting bridge (5). The connecting bridge is frictionlessly mounted on hardened points (6). When the pressure rises the connecting bridge (5) moves upwards and operates the microswitch (7). A counterforce is provided by the spring (8) whose pretension can be modified by the adjusting screw (9) (switching point adjustment). Turning the setting spindle (9) moves the running nut (10) and modifies the pretension of the spring (8). The screw (11) is used to calibrate the microswitch in the factory. The counter-pressure spring (12) ensures stable switching behaviour, even at low setting values.

- 1 = Pressure connection
- 2 = Measuring bellows
- 3 = Sensor housing
- 4 = Thrust pin
- 5 = Connecting bridge
- 6 = Pivot points
- 7 = Microswitch or other switching elements
- 8 = Setting spring
- 9 = Setting spindle (switching point adjustment)
- 10 = Running nut (switching point indicator)
- 11 = Microswitch calibration screw (factory calibration)
- 12 = Counter pressure spring

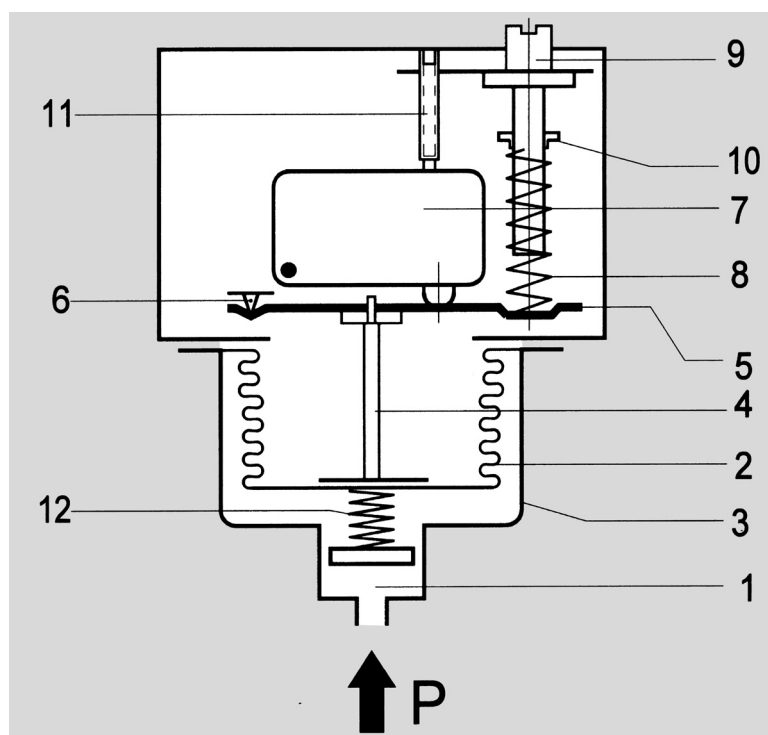

Pressure sensors

Apart from a few exceptions in the low-pressure range, all pressure sensors have measuring bellows, some made of copper alloy, but the majority of high-quality stainless steel. Measured on the basis of permitted values, the measuring bellows are exposed to a minimal load and perform only a small lifting movement. This results in a long service life with little switching point drift and high operating reliability. Furthermore, the stroke of the bellows is limited by an internal stop so that the forces resulting from the overpressure cannot be transmitted to the switching device. The parts of the sensor in contact with the medium are welded together without filler metals. The sensors contain no seals. Copper bellows, which are used only for low pressure ranges, are soldered to the sensor housing. The sensor housing and all parts of the sensor in contact with the medium can also be made entirely from stainless steel 1.4571 (DNS series). Precise material data can be found in the individual data sheets.

Pressure connection

The pressure connection on all pressure switches is executed in accordance with DIN 16288 (pressure gauge connection G 1/2A). If desired, the connection can also be made with a G 1/4 internal thread according to ISO 228 Part 1. Maximum screw-in depth on the G 1/4 internal thread = 9 mm.

Centring pin

In the case of connection to the G 1/2 external thread with seal in the thread (i.e. without the usual sheet gasket on the pressure gauge connection), the accompanying centring pin is not needed. Differential pressure switches have 2 pressure connections (max. and min.) each of which are connected to a G 1/4 internal thread.

General technical data

with microswitches of the DCM, VCM, DNM, DNS and DDC series.

The technical data of type-tested units may differ slightly.
(please refer to type sheet)

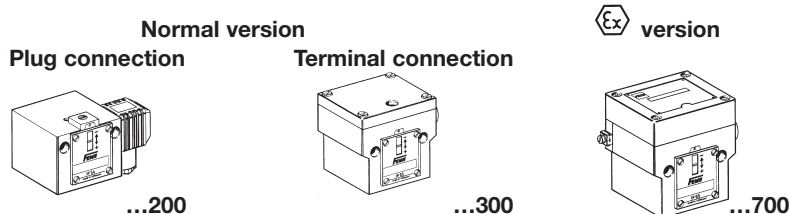

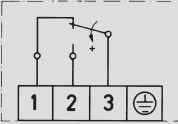
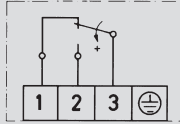
Switch housing	Diecast aluminium GD Al Si 12	Diecast aluminium GD Al Si 12
Pressure connection	G 1/2 external thread (pressure gauge connection) and G 1/4 internal thread G 1/4 internal thread for DDCM differential pressure switches	
Switching function and connection diagram (applies only to version with microswitch)	Floating changeover contact. With rising pressure switching single-pole from 3-1 to 3-2. 	Floating changeover contact. With rising pressure switching single-pole from 3-1 to 3-2. 
Switching capacity (applies only to version with microswitch)	8 A at 250 VAC 5 A at 250 VAC inductive 8 A at 24 VDC 0.3 A at 250 VDC min. 10 mA, 12 VDC	3 A at 250 VAC 2 A at 250 VAC inductive 3 A at 24 VDC 0.03 A at 250 VDC min. 2 mA, 24 V DC
Mounting position	preferably vertical (see technical data sheet)	vertical
Degree of protection (in vertical position)	IP 54; (for terminal connection ...300 IP 65)	IP 65
Ex degree of protection	–	EEx de IIC T6 tested to EN 50014/50018/50019 (CENELEC)
PTB approval Electrical connection	–	PTB 02 ATEX 1121
Cable entry	Plug connection to DIN 43 650 (200 series) or terminal connection (300 series)	Terminal connection
Ambient temperature	PG 11 / for terminal connection M 16 x 1.5	M 16 x 1.5
Switching point	See data sheets Adjustable via spindle. On switching device 300 the terminal box cover must be removed	–15 to +60°C Adjustable via spindle after the terminal box lid is removed
Switching differential	Adjustable or not adjustable (see Product Summary)	Not adjustable
Lead seal	(see Product Summary)	
Medium temperature	Only possible on plug connection housing 200 Max. 70°C, briefly 85°C	Max. 60°C
Vacuum	Higher medium temperatures are possible provided the above limits for the switching device are ensured by suitable measures (e.g. siphon). All pressure switches can operate under vacuum. This will not damage the device.	
Repetition accuracy of switching points	< 1% of the working range (for pressure ranges > 1 bar)	
Vibration strength		
Mechanical life	No significant deviations up to 4 g. With sinusoidal pressure application and room temperature, 10 x 10 ⁶ switching cycles. The expected life depends to a very large extent on the type of pressure application, therefore this figure can serve only as a rough estimate. With pulsating pressure or pressure impacts in hydraulic systems, pressure surge reduction is recommended.	
Isolation values	Overvoltage category III, contamination class 3, reference surge voltage 4000 V.	
Oil and grease-free	Conformity to DIN VDE 0110 (01.89) is confirmed. The parts of all pressure switches with sensors made from steel or stainless steel are oil and grease-free. The sensors are hermetically encapsulated. They contain no seals. (See also additional function ZF 1979 Special Packing)	

ZF additional functions — Pressure switches and pressure monitors

Example for ordering:



DWR 6-205

Code of additional function (e.g. maximum limiter)
Code for pressure range
Sensor system

How to order:

Pressure switch
DWR 6-205
or DWR 6
with ZF 205

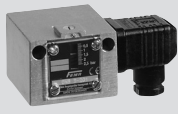
Additional functions / Connection diagrams

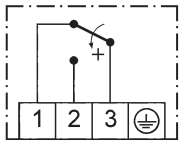
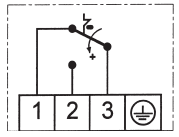
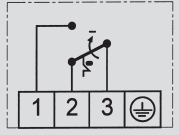
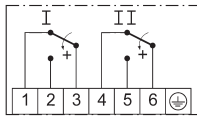
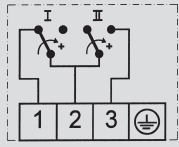
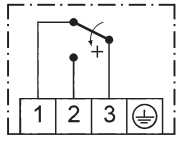
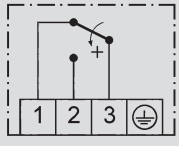
	Plug connection 200 series (IP 54)	Terminal connection 300 series (IP 65)	Connection diagram	Explanation
Normal version (plug connection) Microswitch, single pole switching Switching differential not adjustable				
Terminal connection – housing (300)		...301		
Unit with adjustable switching differential	ZF 203			
Maximum limiter with reclosing lockout Interlocking with rising pressure	ZF 205			see DWR series
Minimum limiter with reclosing lockout Interlocking with falling pressure	ZF 206			see DWR series
Two microswitches , switching in parallel or in succession. Fixed switching interval, only possible with terminal connection housing. State the switching interval (not possible with all pressure switches, see data sheet p. 2, pp. 40 - 43)		ZF 307 *		
Two microswitches, 1 plug switching in succession. adjustable switching interval Please indicate switching scheme* (not possible with all pressure switches, see data sheet p. 2, pp. 40 – 43)	ZF 217 *			
Gold-plated contacts , single pole switching (not available with adjustable switching differential).	ZF 213			Permitted contact load: Max: 24 VDC, 100 mA Min: 5 VDC, 2 mA
Switch housing with surface protection (chemical version).		ZF 351		

*Switching point adjustment: Please specify **switching point and direction of action** (rising or falling pressure).



DWAM...-576

Additional functions for EEx-i equipment ZF 5...

- Housing (300) with terminal connection (IP 65), "blue" cable entry and terminals.
- Also available with resistor combination for line break and short-circuit monitoring (with isolating amplifier Ex 041).

Important:

All pressure switches with the ZF 5... additional functions listed here can only be operated in combination with a suitable isolating amplifier (see pages 60 – 61).

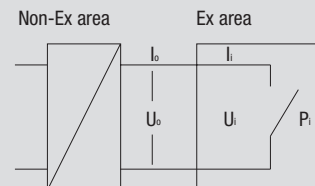

For ZF513, ZF576, ZF574:
 $U_i = 15 \text{ V DC}$, $I_i = 60 \text{ mA}$,
 $P_i = 0.9 \text{ W}$, $C_i < 1 \text{ nF}$, $L_i < 100 \text{ } \mu\text{H}$

Additional functions for EEx-i equipment	Connection diagram	Isolating amplifier
Gold-plated contacts , single-pole switching. Switching differential fixed (not adjustable). Switching capacity: max. 24 VDC, 100 mA, min. 5 VDC, 2 mA.		Ex 011
Versions with resistor combination for line break and short-circuit monitoring in control current circuit, see DBS series, pages 54 – 56:		
Normally closed contact with resistor combination for maximum pressure monitoring , gold-plated contacts, plastic-coated housing (chemical version).		Ex 041
Normally closed contact with reclosing lockout and resistor combination, for maximum pressure monitoring . Plastic-coated housing (chemical version).		Ex 041
Normally closed contact with resistor combination for minimum pressure monitoring , gold-plated contacts, plastic-coated housing (chemical version).		Ex 041
Normally closed contact with reclosing lockout and resistor combination, for minimum pressure monitoring . Plastic-coated housing (chemical version).		Ex 041
Other additional functions	Plug connection 200 series	Terminal connection 300 series
Adjustment according to customer's instruction: one switching point two switching points or defined switching differential	ZF 1970* ZF 1972*	ZF 1970* ZF 1972*
Adjustment and lead sealing according to customer's instruction: one switching point two switching points or defined switching differential	ZF 1971* ZF 1973*	– –
Labelling of units according to customer's instruction with sticker Special packing for oil and grease-free storage	ZF 1978 ZF 1979	ZF 1978 ZF 1979

Documents: Additional documents, e.g. data sheets, operating instructions, TÜV, DVGW or PTB certificates.

Test certificates according to EN 10 204

Factory certificate 2.2 based on non-specific specimen test	WZ 2.2	WZ 2.2
Acceptance test certificate 3.1 based on specific test	AZ 3.1	AZ 3.1
Acceptance test certificate for ZFV separating diaphragms	AZ 3.1 –V	AZ 3.1 –V

***Switching point adjustment:** Please specify **switching point and direction of action** (rising or falling pressure).



Setting instructions

Factory calibration of pressure switches

In view of tolerances in the characteristics of sensors and springs, and due to friction in the switching kinematics, slight discrepancies between the setting value and the switching point are unavoidable. The pressure switches are therefore calibrated in the factory in such a way that the setpoint adjustment and the actual switching pressure correspond as closely as possible in the middle of the range. Possible deviations spread to both sides equally.

The device is calibrated either for falling pressure (calibration at lower switching point) or for rising pressure (calibration at higher switching point), depending on the principal application of the type series in question.

Where the pressure switch is used at other than the basic calibration, the actual switching point moves relative to the set switching point by the value of the average switching differential. As FEMA pressure switches have very small switching differentials, the customer can ignore this where the switching pressure is set only roughly. If a very precise switching point is needed, this must be calibrated and checked in accordance with normal practice using a pressure gauge.

1. Calibration at lower switching point

Setpoint x_s corresponds to the lower switching point, the upper switching point x_o is higher by the amount of the switching differential x_d .

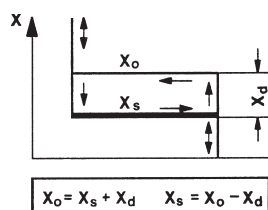

2. Calibration at upper switching point

Setpoint x_s corresponds to the upper switching point, the lower switching point x_u is lower by the amount of the switching differential x_d .

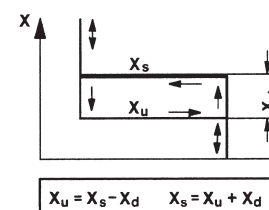

The chosen calibration type is indicated in the technical data for the relevant type series.

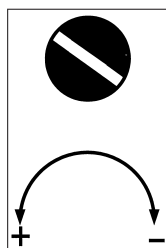

Clockwise:
lower switching
pressure

Anticlockwise:
higher switching
pressure

**Direction of action of setting
spindle**

Setting switching pressures

Prior to adjustment, the securing pin above the scale must be loosened by not more than 2 turns and retightened after setting. The switching pressure is set via the spindle. The set switching pressure is shown by the scale.

To set the switching points accurately it is necessary to use a pressure gauge.

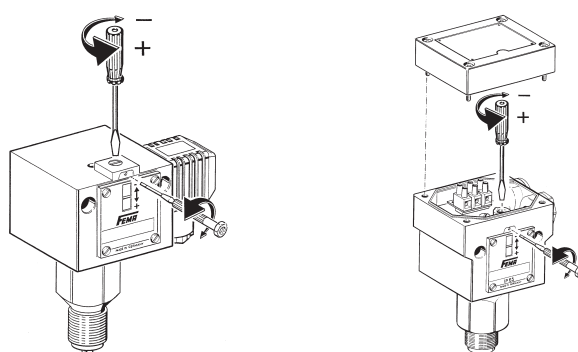

Changing the switching differential (only for switching device with suffix "V", ZF 203)

By means of setscrew within the spindle. The lower switching point is not changed by the differential adjustment; only the upper switching point is shifted by the differential. One turn of the differential screw changes the switching differential by about 1/10 of the total differential range. The switching differential is the hysteresis, i.e. the difference in pressure between the switching point and the reset point.

Lead seal of setting spindle (for plug connection housing 200 only)

The setting spindle for setting the desired value and switching differential can be covered and sealed with sealing parts available as accessories (type designation: P2) consisting of a seal plate and capstan screw. The sealing parts may be fitted subsequently. The painted calibration screws are likewise covered.

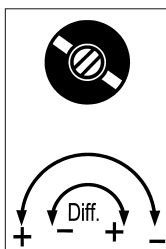

Clockwise:
greater
difference
Anticlockwise:
smaller
difference

**With pressure switches of the
DWAMV and DWR...-203 series,
the direction of action of the
differential screw is reversed.**

Explanation of type designations – type codes

The type designations of FEMA pressure switches consist of a combination of letters followed by a number denoting the setting range. Additional functions and version variants are indicated by a code which is separated from the basic type by a hyphen. Ex versions (explosion protection EEx-d) are identified by the prefix “Ex” in front of the type designation.

Basic version (based on the example of DCM series)	with additional function	Ex-version
DCM XXX	DCM XXX-YYY	Ex-DCM XXX

DCM	—————>	Series code (e.g. DCM)
XXX	—————>	Codes for pressure range
YYY	—————>	Code for additional functions
Ex	—————>	Code for Ex version

Switch housing version	
DCM XXX	Basic version with plug connection housing
DCM XXX-2...	Basic version with plug connection housing
DCM XXX-3...	Terminal connection housing (300)
Ex-DCM XXX	EEx-d switching device (700)
DCM XXX-5...	EEx-i version

Which additional function goes with which pressure switch?

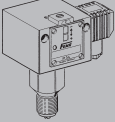
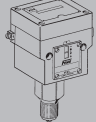
	Plug connection, 200 series 			Terminal connection, 300 series 					
	Additional function ZF			Additional function ZF					
	203	213	217	301	307	513	574 576	575 577	EEx-d
DCM/VCM	• ¹	•	• ¹	•	• ¹	•			•
VNM/DNS/VNS	•	•	•	•	•	•			•
DWAM		•		•		•	•	•	
DDCM		•	• ²	•	• ²	•			•
DWR	•	•		•		•	•	•	•
DGM		•		•		•	•	•	•

• available

¹ except DCM 4016, DCM 4025, VCM 4156 and DCM 1000

² except DDCM 252, 662, 1602, 6002

**Ex-versions (EEx-d) can only be supplied in basic form.
Additional functions are not possible.**

S2 type series

Pressure switches with 2 microswitches – technical data

FEMA pressure switches of the **DCM** (except DCM 1000, DCM 4016 and DCM 4025), **VCM** (except VCM 4156), **VNM, DNS, VNS** series and the differential pressure monitor **DDCM** (except DDCM 252, 662, 1602, 6002) can be

equipped with 2 microswitches (see also the table on page 41).

This is not possible with any other type series or with Ex versions.

Technical data

Standard equipment

The standard equipment of every two-stage pressure switch includes a switching device with 2 microswitches, both single-pole switching. Switch I monitors the low pressure, switch II the higher pressure. The setting ranges indicated in the data sheets for the basic types apply to the two-stage pressure switches as well. It should be noted that the switching differentials of the individual microswitches may not be exactly the same due to component tolerances.

Switching interval

The switching interval of the two microswitches is the difference (in bar or mbar) between the switching points of the two microswitches.

For example:

When the pressure rises, a two-stage pressure switch turns on a warning light (e.g. 2.8 bar), and if the pressure continues to rise (e.g. 3.2 bar) the system shuts down. The switching interval is $3.2 - 2.8 = 0.4$ bar. For all versions the rule is:

The switching interval remains constant over the whole setting range of the pressure switch. If the switching pressure setting is changed with the setting spindle, the switching interval does not change – the switching points are moved in parallel.

Switching differential

The switching differential, i.e. the hysteresis of the individual microswitches, corresponds to the values of the relevant basic design referred to in the Product Summary. In the case of two-stage pressure switches, **the switching differential of the individual microswitches is not adjustable.**

Versions

Two-stage pressure switches are available in three different versions, each identified by a ZF number. The versions differ in terms of their connection schemes and electrical connection types (terminal or plug connection).

The applicable data sheet for the basic types contains the technical data for the two-stage pressure switches. This includes all limits of use, temperature, maximum pressure, mounting position, type of protection, electrical data etc. The principal dimensions are the same as for single-stage pressure switches, with similar pressure ranges and design features.

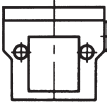
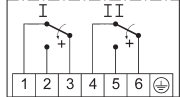
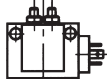
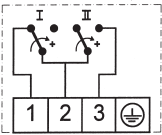
Additional function	Switching interval between the two microswitches	Electrical connection	Connection diagram	Ordering information required
<p>ZF 307</p> 	<p>Factory setting according to customer-specifications</p>	<p>Terminal connection (All terminals of both microswitches are accessible (6 terminals))</p>	<p>2 x single pole switching.</p> 	<ol style="list-style-type: none"> 1. Basic type with ZF 307 2. Switching points I and II, with direction of action in each case (rising or falling pressure). Example: DCM 16-307 Switching point I: 10 bar falling Switching point II: 12 bar falling or switching interval only.
<p>ZF 217</p> 	<p>Adjustable via adjustment knobs I and II according to "Switching intervals" table</p>	<p>Plug connection according to DIN 43 650 (3-pole + ground conductor) Function-appropriate internal wiring according to "Switching functions" table</p>	<p>Example selection according to "Switching schemes" table, page 42.</p> 	<ol style="list-style-type: none"> 1. Basic type with ZF 217 2. Switching scheme Example: DCM 16-217/B 4 Since all values are adjustable within the specified limits, no further data is required.

S2 type series (selection)

ZF 217 pressure switches with two microswitches and switching intervals

Switching intervals of two-stage pressure switches (ZF 217, ZF 307)

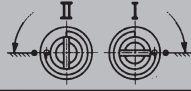
Type series S2 ZF 217 ZF 307				
	min. switching interval	max. switching interval (average values)		
Type	Factory default	Switching scheme A1/A3/B2/B4 C1/C3/D2/D4 + ZF 307	Switching scheme A2/A4/C2/C4	Switching scheme B1/B3/D1/D3
DCM 06	40 mbar	165 mbar	190 mbar	140 mbar
DCM 025	20 mbar	140 mbar	160 mbar	120 mbar
DCM 1	40 mbar	240 mbar	280 mbar	200 mbar
DCM 3	0.1 bar	0.65 bar	0.75 bar	0.55 bar
DCM 6	0.15 bar	0.95 bar	1.2 bar	0.8 bar
DCM 10	0.25 bar	1.6 bar	1.85 bar	1.35 bar
DCM 16	0.3 bar	2.0 bar	2.3 bar	1.7 bar
DCM 25	0.6 bar	4.0 bar	4.6 bar	3.4 bar
DCM 40	0.9 bar	6.0 bar	6.9 bar	5.1 bar
DCM 63	1.3 bar	8.5 bar	9.8 bar	7.2 bar
DDCM 1	0.09 bar	0.55 bar	0.64 bar	0.46 bar
DDCM 6	0.14 bar	0.94 bar	1.08 bar	0.8 bar
DNM 025	35 mbar	215 mbar	240 mbar	180 mbar
VCM 095	40 mbar	300 mbar	340 mbar	260 mbar
VCM 101	40 mbar	260 mbar	300 mbar	220 mbar
VCM 301	20 mbar	100 mbar	120 mbar	80 mbar
VNM 111	50 mbar	310 mbar	360 mbar	260 mbar

Switching devices with adjustable switching interval

Additional function ZF 217

On switching devices with additional function ZF 217, the switching interval is continuously adjustable via two adjustment knobs I and II accessible from outside. The maximum switching intervals are stated in the "Switching intervals" table.

Turning adjustment knob I clockwise produces a lower switching point for microswitch I.

Turning adjustment knob II anticlockwise produces a higher switching point for microswitch II.

Adjustment knobs I and II have an internal stop to prevent the microswitches from being adjusted beyond the effective range.

Adding together the adjustments on knobs I and II gives the switching interval between the two microswitches. Changes made with the setting spindle do not affect the switching interval. The switching interval remains constant over the whole setting range of the spindle. The two switching points are moved up or down in parallel.

Recommended adjustment method for switching devices with ZF 217

- Set adjustment knobs I and II to their basic positions.
Turn adjustment knob I as far as possible anticlockwise.
Turn adjustment knob II as far as possible clockwise.
- Adjust the setting spindle **S** by the scale to a value midway between the desired upper and lower switching points.
- With pressure applied, set the lower switching point with adjustment knob I.
- In the same way as in step 3, set the upper switching point with adjustment knob II.
- If the desired upper and lower switching points cannot be reached, turn the setting spindle **S** in the appropriate direction and repeat steps 3 and 4.

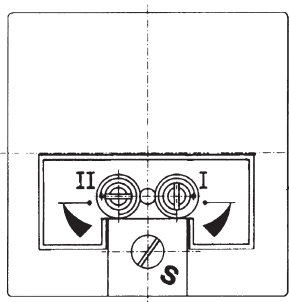

S2 type series

Two-stage pressure switches, switching schemes for ZF 217

Function-appropriate internal configuration of microswitches I and II, switching scheme selection table. The switch position shown corresponds to the pressureless state. On the horizontal axis is the switching function of microswitch I (A–D); on the vertical axis is the switching function of microswitch II (1–4). At the intersection is the switching scheme which satisfies both conditions (e.g. A 2).

		Microswitch I (lower switching point)			
		A falling, close	B rising, close	C falling, open	D rising, open
Microswitch II (upper switching point)	1 falling, close				
	2 rising, close				
	3 falling, open				
	4 rising, open				

Information required when ordering:

As well as the basic type (e.g. DCM 10) and the switching scheme (e.g. A 2), for factory setting it is also necessary to indicate the switching points and direction of action:

Example: DCM 10-217 / A 2 Switch I: 6.5 bar falling, Switch II: 7.5 bar rising.

S2 type series

Examples of use for two-stage pressure switches

Pressure monitoring and controlling can be greatly simplified by using pressure monitors with two built-in microswitches which can be made to operate one after the other under rising or falling pressure. For example, minimum and maximum pressure monitoring can be achieved with only **one** pressure switch, doing away with the need for a second pressure switch (including the cost of installation). Step switching, e.g. pressure-dependent control of a two-stage pump, is of course also possible using this special series.

For pressure-dependent control of automatic expansion valves and pressure holding devices

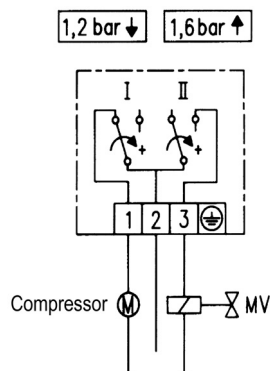

Example 1:

Requirement

Pressure holding devices and automatic expansion valves usually have a gas cushion whose pressure must be kept constant within a certain range. If the pressure is too low, a compressor is switched on. If the pressure is too high, a solenoid valve must be opened to vent the gas. Between these two levels is a neutral zone, in which the compressor and the solenoid valve are at rest.

Solution

All pressure switches of types DCM, DNM, DNS, each with additional function ZF 217 and switching scheme A 2, are suitable. All pressure ranges listed in the technical documents are possible. Example for ordering: DCM 6-217/A 2

Switching function / connection scheme

Switch I: With falling pressure, contact 1–2 closes (compressor on)
With rising pressure, contact 1–2 opens (compressor off)

Switch II: With rising pressure, contact 2–3 closes (valve open)
With falling pressure, contact 2–3 opens (valve closed).
In between there is a neutral zone in which the compressor is not switched on and the solenoid coil is not energized (off position).

Minimum and maximum pressure monitoring in a nitrogen line

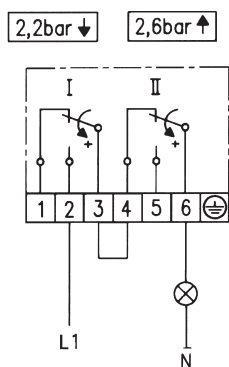

Example 2:

Requirement

In a process engineering system, the pressure in a nitrogen line has to be monitored. A green signal lamp indicates that the pressure in the line is between 2.2 and 2.6 bar. If the pressure goes below 2.2 bar or above 2.6 bar, the indicator lamp goes out and the system shuts down.

Solution

The first contact of a DCM 3–307 pressure switch with 2 microswitches opens under falling pressure at 2.2 bar; the second microswitch opens under rising pressure at 2.6 bar. If the pressure is >2.2 bar and <2.6 bar, the circuit is closed via both microswitches and the signal lamp is lit.

Example 3:

Filter monitoring with a 2-stage differential pressure switch

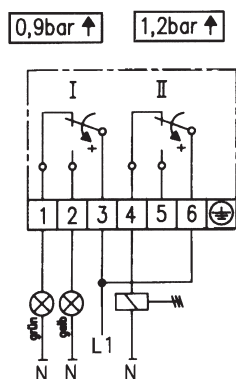

Requirement

The gradual fouling of a filter system is to be monitored by a differential pressure switch. Increased fouling causes a higher differential pressure between the input and the output of the filter system. A green signal lamp indicates the normal operating state. If fouling reaches a certain value (differential pressure >0.9 bar), a yellow signal lamp warns the operator that it is time to change the filter elements. If this is not done and the differential pressure rises due to further fouling (e.g. to >1.2 bar), the system must be shut down.

Solution

A differential pressure switch DDCM 6–307 operates under rising differential pressure (at 0.9 bar), the green control lamp goes out; at the same time the yellow lamp comes on (warning that it is time to clean the filter). If the differential pressure continues to rise (to >1.2 bar), the circuit opens via 4–6 of the second microswitch, the relay drops out and the system shuts down.



VCM 301

VNM 111

VCM type series

Negative pressure switches (vacuum switches)

FEMA negative pressure switches detect the pressure difference relative to atmospheric pressure. All data relating to the setting range and thus also the scale divisions on the switching devices are to be understood as the difference in pressure between the relevant atmospheric pressure and the set switching pressure.

The "zero" reference point on the scale of the unit corresponds to the relevant atmospheric pressure. A minus sign before the pressure value signifies negative pressure below the relevant atmospheric pressure.

Technical data

Pressure connection

External thread G 1/2 (pressure gauge connection) according to DIN 16 288 and internal thread G 1/4 according to ISO 228 Part 1.

Switching device

Robust housing (200) made of seawater-resistant diecast aluminium GD Al Si 12.

Degree of protection

IP 54, in vertical position.
IP 65, for EEx-d version.

Pressure sensor materials

VNM 111 and VNM 301: Metal bellows: 1.4571
Sensor housing: 1.4104
VCM 095, 101 and 301: Metal bellows of Cu Zn
Sensor housing of CuZn
VCM 4156: Perbunan diaphragm sensor housing: 1.4301

Mounting position

Vertically upright and horizontal.
VCM 4156 vertically upright.

Ambient temp. at switching device

-25...+70 °C
For EEx-d versions: -15...+60 °C

Max. medium temperature

The maximum medium temperature at the pressure sensor must not exceed the permitted ambient temperature at the switching device. Temperatures may reach 85°C for short periods (not EEx-d). Higher medium temperatures are possible provided the above limit values for the switching device are ensured by suitable measures (e.g. siphon).

Mounting

Directly on the pressure line (pressure gauge-connection) or on a flat surface with two 4 mm Ø screws.

Switching pressure

Adjustable from outside with screwdriver.

Switching differential

Not adjustable with VCM and Ex-VCM types.
Adjustable with VCM-203 type.
For values see Product Summary.

Contact arrangement

Single-pole changeover switch.

Switching capacity	250 VAC (ohm)	250 VDC (ind)	24 VDC (ohm)	24 VDC (ohm)
Normal	8 A	5 A	0.3 A	8 A
EEx-d	3 A	2 A	0.03 A	3 A

Product Summary

Type	Setting range	Switching differential (mean values)	Max. permissible pressure	Dimensioned drawing
------	---------------	--------------------------------------	---------------------------	---------------------

Switching differential not adjustable

VCM 4156	-15...+6 mbar	2 mbar	1 bar	1 + 11
VCM 301	-250...+100 mbar	25 mbar	1.5 bar	1 + 13
VNM 301	-250...+100 mbar	45 mbar	3 bar	1 + 15
VCM 101	-1*...+0.1 bar	45 mbar	3 bar	1 + 14
VCM 095	-0.9...+0.5 bar	50 mbar	3 bar	1 + 14
VNM 111	-1*...+0.1 bar	50 mbar	6 bar	1 + 15

Switching differential adjustable

VCM 301-203	-250...+100 mbar	30-200 mbar	1.5 bar	1 + 13
VNM 301-203	-250...+100 mbar	70-500 mbar	3 bar	1 + 15
VCM 101-203	-1*...+0.1 bar	80-350 mbar	3 bar	1 + 14
VCM 095-203	-0.9...+0.5 bar	90-400 mbar	3 bar	1 + 14
VNM 111-203	-1*...+0.1 bar	90-650 mbar	6 bar	1 + 15

Ex version, (housing 700), explosion protection EEx-d

Ex-VCM 4156	-15...+6 mbar	2 mbar	1 bar	3 + 11
Ex-VCM 301	-250...+100 mbar	25 mbar	1.5 bar	3 + 13
Ex-VNM 301	-250...+100 mbar	45 mbar	3 bar	3 + 15
Ex-VCM 101	-1*...+0.1 bar	45 mbar	3 bar	3 + 14
Ex-VCM 095	-0.9...+0.5 bar	50 mbar	3 bar	3 + 14
Ex-VNM 111	-1*...+0.1 bar	50 mbar	6 bar	3 + 15

* At very high vacuums, close to the theoretical maximum of -1 bar, the switch may not be usable in view of the special conditions of vacuum engineering. However, the pressure switch itself will not be damaged at maximum vacuum.

For additional functions refer to ZF data sheet.

For smaller pressure ranges see also HCD and DPS data sheets.

Calibration

The **VCM** and **VNM** series are calibrated for falling pressure. This means that the adjustable switching pressure on the scale corresponds to the switching point at falling pressure. The reset point is higher by the amount of the switching differential. (See also page 30, 1. Calibration at lower switching point).

Dimensioned drawings of switch housings

1 Housing 200 (plug connection)

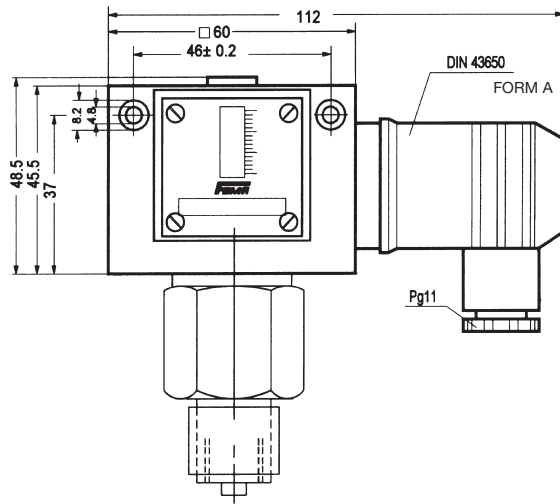

2 Housing 300 and 500 (terminal connection)

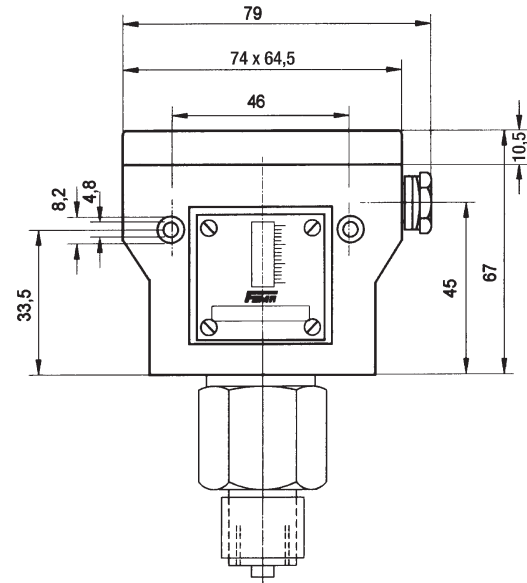

3 Housing 700 (Ex)

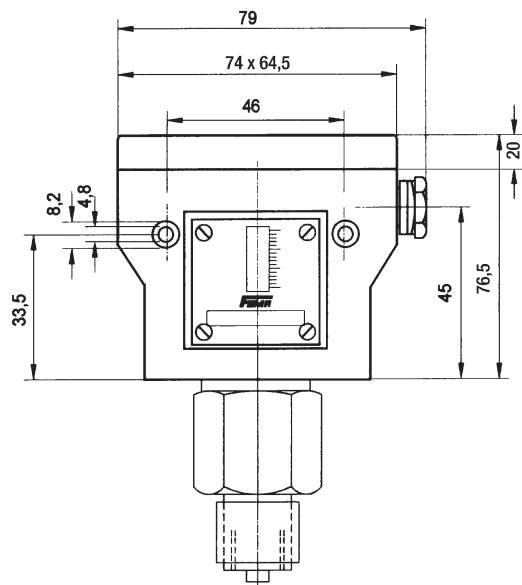

Dimensioned drawings of pressure sensors

10

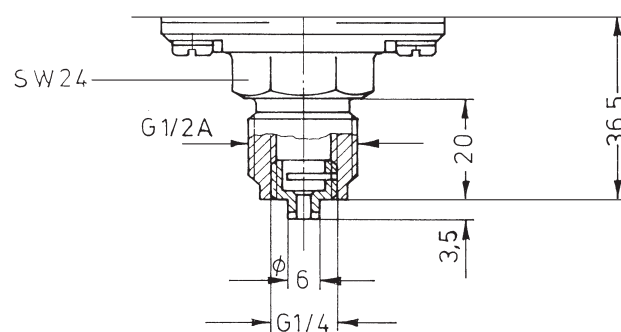

11

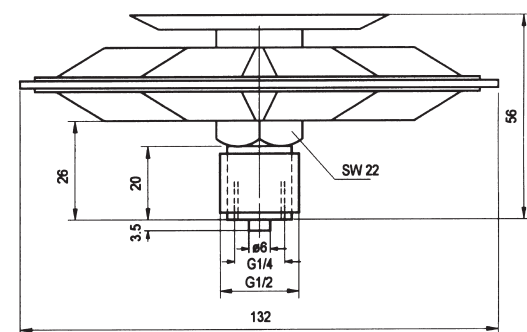

Dimensioned drawings of pressure sensors

12

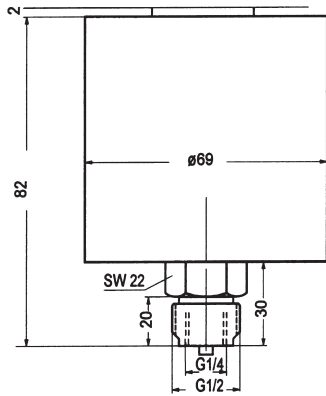

13

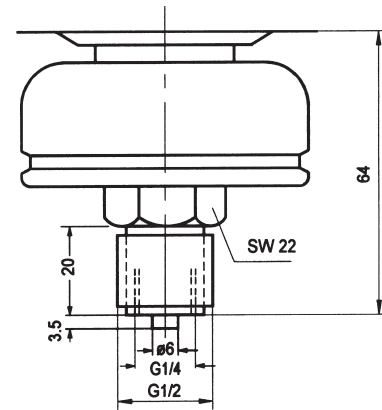

14

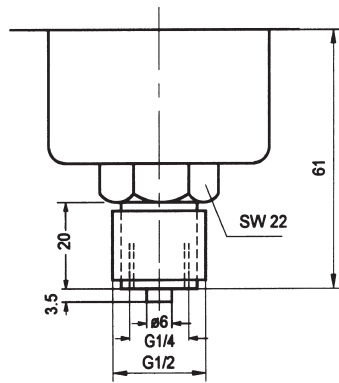

15

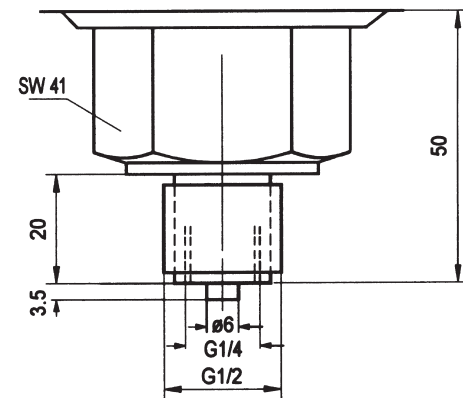

16-19

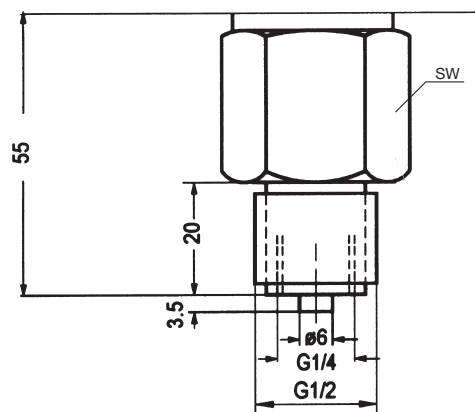

Dimensioned drawing	SW
16	22
17	24
18	30
19	32

20

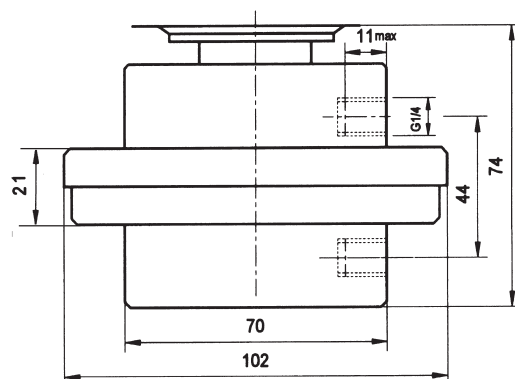

21

